



**THE EXHIBITORS'
HAND
BOOK**
MODULAR DISPLAY SOLUTIONS

BANNER STANDS | RETRACTABLE..... 1-6

BANNER STANDS | TELESCOPIC..... 7-8

BANNER STANDS | SPRING BACK..... 9-11

OUTDOOR PRODUCTS..... 12-15

BACKWALLS & INFO CENTERS 16

VECTOR FRAME | TENSION FABRIC WALLS & EXHIBITS... 17-19

HOPUP | TENSION FABRIC DISPLAY SYSTEMS..... 20-21

POPOP DISPLAY SYSTEMS | CASES..... 22-26

FORMULATE | TENSION FABRIC EXHIBITS..... 27-30

FORMULATE | FABRIC HANGING STRUCTURES 31-33

VIBE | TENSION FABRIC EXHIBITS..... 34-35

TABLE THROWS AND RUNNERS 36-37

FOLDING DISPLAY PANELS..... 38-41

ORBITAL EXPRESS TRUSS 42-58

LINEAR DISPLAY SYSTEMS..... 59-63

KIOSKS..... 64-65

COUNTERS..... 66-67

DISPLAY ADDITIONS..... 68

LITERATURE RACKS 69

CASES & CRATES 70-71

LUMINOSITY | DISPLAY LIGHTING 72

SYMBOLS USED IN THE EXHIBITORS' HANDBOOK:



premium product



product can be recycled
(does not include graphic application)



product made in the U.S.



standard product



new addition to
The Exhibitors' Handbook



economy product



product comes with
a carry bag or case

WARRANTY KEY:



lifetime warranty
(hardware)



90 day warranty
(hardware)



5 year warranty
(hardware)



graphics limited
1 year warranty
(indoor products)



1 year warranty
(hardware)



graphics limited
6 month warranty
(outdoor and table
throw products)

BLADE LITE

23.5" WIDE BLD-LT-600

36" WIDE BLD-LT-920

47.25" WIDE BLD-LT-1200

59" WIDE BLD-LT-1500

- four widths to choose from: 23.5", 36", 47.25", 59"
- premium top rail
- weighted base for stability
- adjustable leveling feet
- 3-piece bungee pole



PREMIUM RETRACTABLE BANNER STANDS



Premium Retractable banner stands provide superior, high-end functionality, features and durability, as well as unique styling points for exceptional appearance. Premium banners include a protective, molded carry bag and feature a lifetime hardware warranty.



IMAGINE

31.5" WIDE IMG-800-S

- variable height = 29.5" - 83.35"
- graphic tensioner
- integrated pole storage
- interchangeable graphic cassette
- adjustable feet on base
- telescopic pole



BARRACUDA

31.5" WIDE BCD-800-S
BCD-800-B

- variable height = 29.5" - 83.35"
- graphic tensioner
- integrated pole storage
- anodized silver or black
- adjustable feet on base
- telescopic pole



ADVANCE

31.5" WIDE ADV-800-S

- variable height = 29.5" - 83.35"
- double sided
- graphic tensioner
- integrated pole storage
- interchangeable graphic cassette
- adjustable feet on base
- telescopic pole



EXCALIBUR

31.5" WIDE EXC-800-S
EXC-800-B

- variable height = 29.5" - 83.35"
- double sided
- graphic tensioner
- integrated pole storage
- adjustable feet on base
- telescopic pole





STANDARD RETRACTABLE BANNER STANDS

Standard Retractable banner stands incorporate customary features designed to provide everyday reliability, durability and ease of use. Standard banners include a mid-range canvas carry bag and typically feature a five-year to lifetime hardware warranty.



ORIENT

31.5" WIDE silver: ONT-800-S-3
black: ONT-800-B-3

35.5" WIDE silver: ONT-920-S-3
black: ONT-920-B-3

39.25" WIDE silver: ONT-1000-S-3
black: ONT-1000-B-3

- standard height = 85.04"
- anodized silver or black
- molded end caps
- adjustable feet on base
- 3-piece bungee pole



ORIENT 2

31.5" WIDE silver: ONT-800-DBL-S-3
black: ONT-800-DBL-B-3

35.5" WIDE silver: ONT-920-DBL-S-3
black: ONT-920-DBL-B-3

39.25" WIDE silver: ONT-1000-DBL-S-3
black: ONT-1000-DBL-B-3

- standard height = 85.04"
- double-sided
- anodized silver or black
- molded end caps
- adjustable feet on base
- 3-piece bungee pole



PACIFIC

31.5" WIDE PAC-800-S-2

35.5" WIDE PAC-920-S-2

39.25" WIDE PAC-1000-S-2

- standard height = 83.75"
- anodized silver
- molded end caps
- swivel-out foot
- 3-piece bungee pole



CONTENDER

23.5" WIDE silver: CN-24-S
black: CN-24-B

29.5" WIDE silver: CN-30-S
black: CN-30-B

35.5" WIDE silver: CN-36-S
black: CN-36-B

47.5" WIDE black: CN-48-B

- standard height = 77.5"
- swivel-out foot
- silver or black finish
- laser cut steel ends & swaged pole



STANDARD RETRACTABLE BANNER STANDS



Standard Retractable banner stands incorporate customary features designed to provide everyday reliability, durability and ease of use. Standard banners include a mid-range canvas carry bag and typically feature a five-year to lifetime hardware warranty.

BANNER STANDS | RETRACTABLE

STANDARD

ELEVATE

33.5" WIDE ELEVATE

- over 8' tall
- variable height = 33.25" – 96"
- roller access via flip-top lid and removable self-locking graphic roller mechanism
- black aluminum body with chrome end caps
- telescopic pole (4 segments)



BLADE LX

33.5" WIDE BLD-LX-GRY

- standard height = 83.25"
- anodized gunmetal finish
- removable self-locking graphic roller mechanism
- graphic slider
- adjustable feet on base
- premium top rail
- 3-piece bungee pole



ORCHID

33.5" WIDE ORCHID

- standard height = 76.75"
- quick to assemble and easy to use
- bamboo base, rail and pole are a sustainable & eco-friendly choice
- slide graphic rail
- 3-piece pole



BLOK

33.5" WIDE BLOK-850

- standard height = 79.25"
- black base with chrome end caps
- 3-piece bungee pole



NEW



90 DAY

ECONOMY RETRACTABLE BANNER STANDS

Economy Retractable banner stands incorporate basic design features, functionality and reliability. Economy banners include a basic carry bag and feature a 90-day hardware warranty.

BANNER STANDS | RETRACTABLE

ECONOMY



START

31.5" WIDE STRT-800

- standard height = 83.125" h
- snap top graphic rail
- swivel foot
- anodized silver finish
- 3-piece bungee pole



FREEDOM

31.5" WIDE FRDM-800

39.25" WIDE FRDM-1000

- standard height = 82.75" h
- snap top graphic rail
- 3-piece bungee pole



MSQT-1500



MSQT-1200



MSQT-800

MOSQUITO

31.5" WIDE MSQT-800

47.25" WIDE MSQT-1200

59" WIDE MSQT-1500

- standard height = 82.87" h
- anodized silver
- swivel-out foot
- snap top graphic rail
- 3-piece bungee pole



ECONOMY RETRACTABLE BANNER STANDS

Economy Retractable banner stands incorporate basic design features, functionality and reliability. Economy banners include a basic carry bag and feature a 90-day hardware warranty.



RETRACTOR 4

32.75" WIDE RTRC-4

- standard height = 78.25"
- double sided
- snap top graphic rail
- 3-piece bungee pole



RETRACTOR 5

36" WIDE RTRC-5

- standard height = 79.375"
- velcro graphic application
- snap top graphic rail
- 3-piece bungee pole

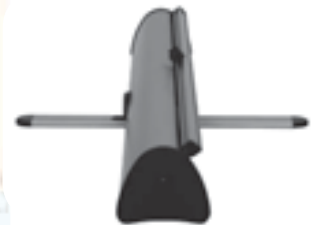

QUICK WALL

QWK

- standard height = 78.5"
- unit width: 32"
- graphic width: 31.5"
- kit includes 3 Mosquito 800 banner stands and 1 OCB banner stand case
- snap top graphic rail





STANDARD TELESCOPIC BANNER STANDS

Standard Telescopic banner stands incorporate customary features designed to provide everyday reliability, durability and ease of use. Standard banners include a mid-range canvas carry bag and typically feature a five-year hardware warranty.

PEGASUS MINI

27.5" - 48" WIDE silver: PGSUS-MIN-S black: PGSUS-MIN-B

PEGASUS

52.5" - 95" WIDE silver: PGSUS-S black: PGSUS-B

- single or double-sided graphics
- allows for custom size graphics
- easy to store
- steel feet for stability
- telescopic pole for adjustable graphic width and height



Pegasus Mini

Pegasus



DASH 1 & 2

31.5" WIDE single sided: DSH-M-1 double sided: DSH-M-2

- variable height = 31.5" - 78.5"
- stable, anodized aluminum
- quick & easy to erect



DASH MEGA 1 & 2

36" WIDE single sided: DSH-ME double sided: DSH-ME-2

- variable height = 36" - 93.5"
- stable, anodized aluminum
- quick & easy to erect



STANDARD TELESCOPIC BANNER STANDS



Standard Telescopic banner stands incorporate customary features designed to provide everyday reliability, durability and ease of use. Standard banners include a mid-range canvas carry bag and typically feature a five-year hardware warranty.



DASH LITERATURE POCKET

31.5" WIDE DSH-M-LR

- recommended graphic height = 44"
- 3 pocket literature dispenser option to attach to a Dash unit



UNO

31.5" WIDE UN-1-ST

36" WIDE UN-1-MG

48" WIDE UN-1-MO

- variable height = 35" - 85.5"
- powder coated black weighted base



TELESCOPIC 1

23.5" WIDE TEL-1-A

- variable height = 36" - 70"
- single or double sided



TELESCOPIC 4

31" WIDE TEL-4

- variable height = 31" - 77"
- telescopic pole





STANDARD SPRING BACK BANNER STANDS

Standard Spring Back banner stands incorporate customary features designed to provide everyday reliability, durability and ease of use. Standard banners include a mid-range canvas carry bag and typically feature a one-year hardware warranty.

BANNER STANDS | SPRING BACK

STANDARD



LIGHTNING

31" WIDE LTNG

- standard height = 77"
- snap-lock graphic rails
- 3-piece bungee pole

ECONOMY SPRING BACK BANNER STANDS



Economy Spring Back banner stands incorporate basic design features, functionality and reliability. Economy banners include a basic carry bag and feature a 90-day hardware warranty.



SPRING 1-1

24"
WIDE SB-1-1

- height = 59" or 78.5"



SPRING 1-2

27"
WIDE SB-1-2

- height = 59" or 78.5"



SPRING 1-3

35.25"
WIDE SB-1-3

- height = 59" or 78.5"



SPRING 3

27.5"
WIDE SB-3

- standard height = 70.75"
- #3 grommets in corners
- single or double sided





ECONOMY SPRING BACK BANNER STANDS

Economy Spring Back banner stands incorporate basic design features, functionality and reliability. Economy banners include a basic carry bag and feature a 90-day hardware warranty.



SPRING 4

27"
WIDE SB-4

- standard height = 60"
- #3 grommets in corners



SPRING 6

24.5"
WIDE SB-6

- standard height = 63"
- #3 grommets in corners



SPRING 7

29.5"
WIDE SB-7

- variable height = 61.5" - 69"
- #3 grommets in corners



SCROLLER 1

28.75"
WIDE SC-1

- variable height = 48" - 72"
- top scrolling mechanism allows for a variety of lengths and styles
- utilizes standard 110v power

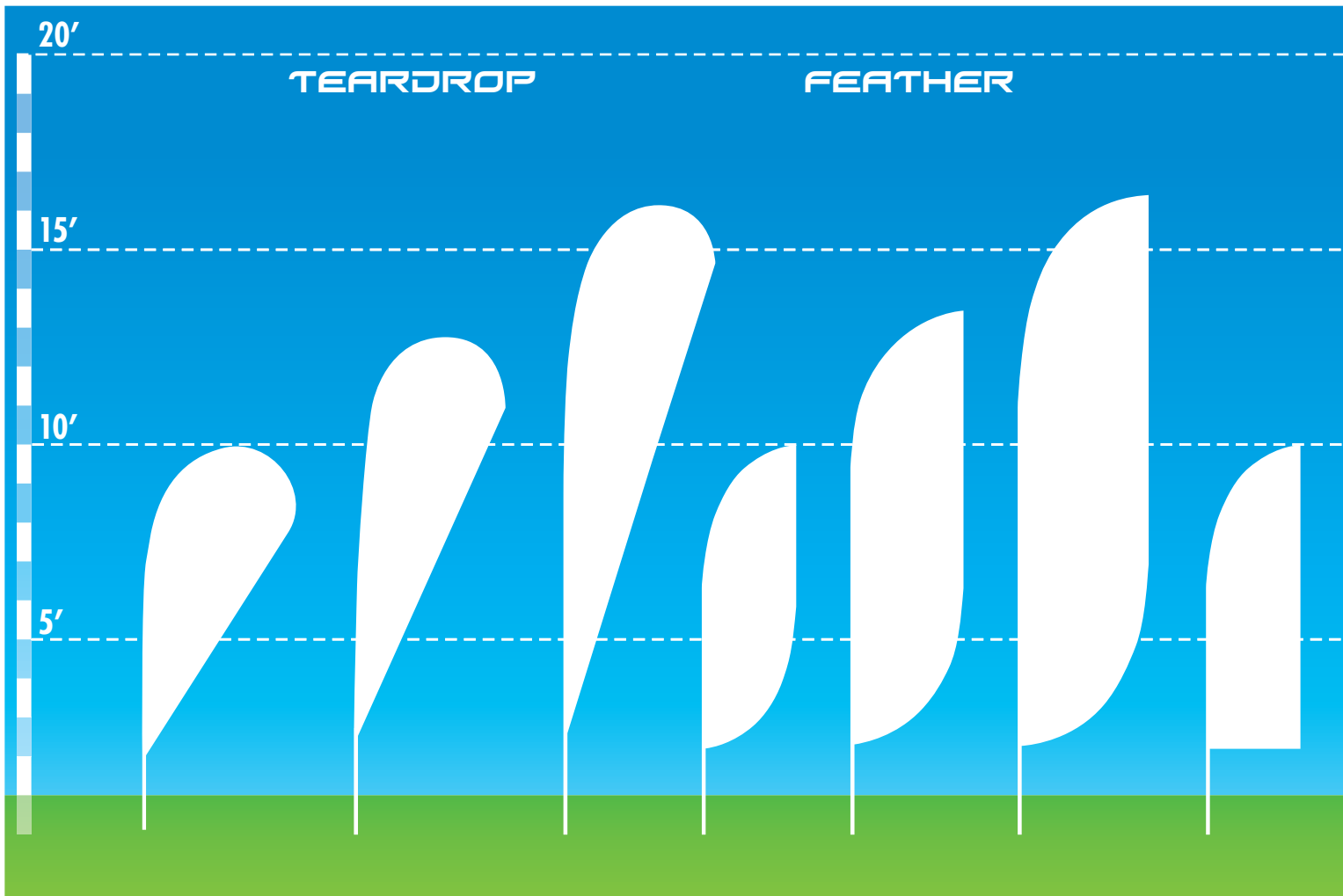

ZOOM LINE

- can be used indoors or out
- graphic rotates in wind
- water fillable donut adds stability to quad leg (included)
- graphic printed on flag material
- double sided graphic available
- both floor base & ground stake included

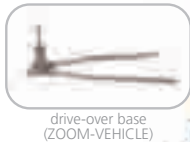

shown with quad leg and water fillable donut

WIND DANCER LT

31.5" WIDE WIND-LT

- adjustable height = up to 13'6"
- hollow base can be filled with either water or sand as weighing agent



Wind Dancer Lanyard allows a standard Wind Dancer or Wind Dancer LT to be converted into a flagpole. WND-MX-FPCK



All Outdoor products have a one year hardware warranty and are eco-friendly.

STRAIGHT

WIND DANCER

BLAST

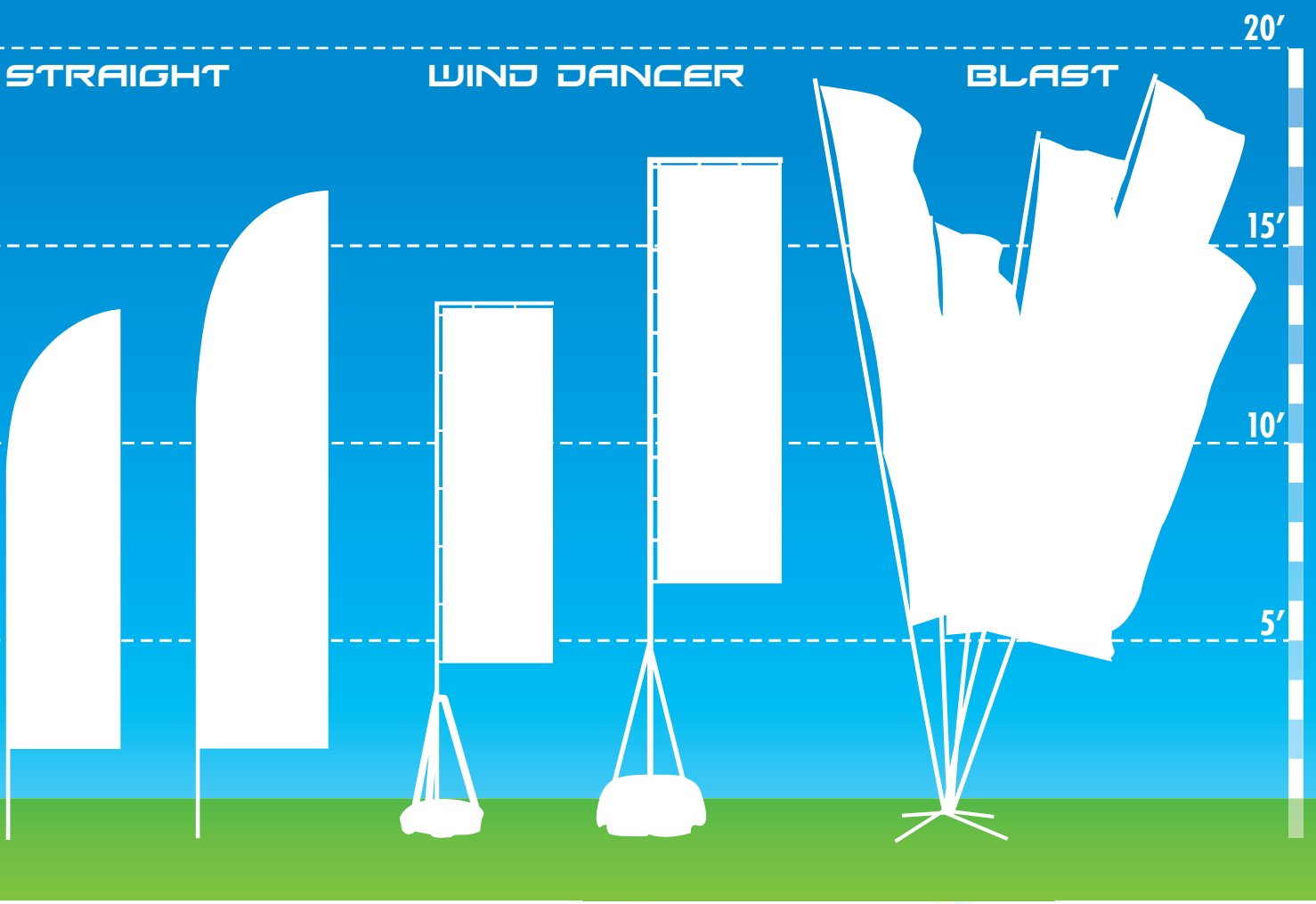

WIND DANCER

43" WIDE WIND-MX

- adjustable height = up to 17'3"
- flag is approximately 43" wide
- hollow base can be filled with either water or sand as weighing agent



Wind Dancer Spire allows a standard Wind Dancer or Wind Dancer LT to be converted into a double-sided "V" shape banner, not intended for outdoor use. WND-MX-FPCK2

BLAST

- approx. 19'8" high
- display a single flag or as many as 5
- bungee cord poles fabricated from hybrid aluminum/steel
- powder coated steel base
- comes with 4 ground spikes & rubber mallet



All Outdoor products have a one year hardware warranty and are eco-friendly.

SPINNAKER

8'7" TALL SPKR

- maximum graphic area of 8'w x 8'h (weather & wind conditions permitting)
- portable outdoor billboard
- single or double sided



MONSOON

MONSN-2



- visual area = approx. 92" w x 33" h
- semi-portable single or double sided billboard
- includes ground stakes & bungee rope



SPRING 5



31.5" WIDE SB-5

- standard height = 70.75"
- indoor or outdoor use
- single or double sided
- base can be filled with water or sand
- easy grommet graphic attachment
- tension pole system



BLIZZARD



BLZD

- max width x min height: 40" w x 49.5" h
- min width x max height: 23.5" w x 80" h
- max width x max height: 40" w x 74.5" h
- min width x min height: 23.5" w x 49.5" h
- outdoor bannerstand
- base can be filled with water or sand
- easy grommet graphic attachment



All Outdoor products have a one year hardware warranty and are eco-friendly.

PARKWAY

single span: PKWY-S-SPN
 double span: PKWY-D-SPN

- single sided = 32"l x 60"h
- double sided = 67"l x 60"h
- withstands winds up to 38MPH
- single or double span street pole banner



ROCKET

- graphic area = 24"w x 36"h
- 3 legs can be filled with water or sand
- single or double sided
- spring-loaded graphic support
- 1/8" coroplast plastic or similar substrate recommended
- ideal for contour cut custom graphics
- graphic size may vary



BRUTE
BRUTE

- use one to hold a smaller graphic, or as many as you need to hold a large graphic
- secure grip allows for use outdoors in the elements as well as inside
- quick set-up, easy storage
- fill with water or sand, 100% emptied after use
- works with a variety of graphic substrates



contoured base sits stable on uneven terrain

recommended width:
 1 Brute per 4' of signage

WHIRLWIND
WHRL-WND-1

- 31.1"w x 45.7"h x 19.7"d
- front-loading snap frames constructed from aluminum & powder-coated steel
- single or double sided
- includes clear lens cover
- dual-spring design flexes to withstand wind gusts
- compact durable base can be filled with water or sand for extra stability
- integrated wheel set



All Outdoor products have a one year hardware warranty and are eco-friendly.

AERO



- indoor modular display system
- adjustable heights & angles
- shown with optional Lumina 200 floodlights
- available "à la carte" to create more combinations

Aero Basic Kit:

AERO-1200-BASIC

- comes with 3 1200mm cassettes and 4 uprights with base

Aero Complete Kit:

AERO-1200-KIT

- comes with 3 1200mm cassettes in an OCH2 case and 2 120 watt lights, no graphics (must ship freight)

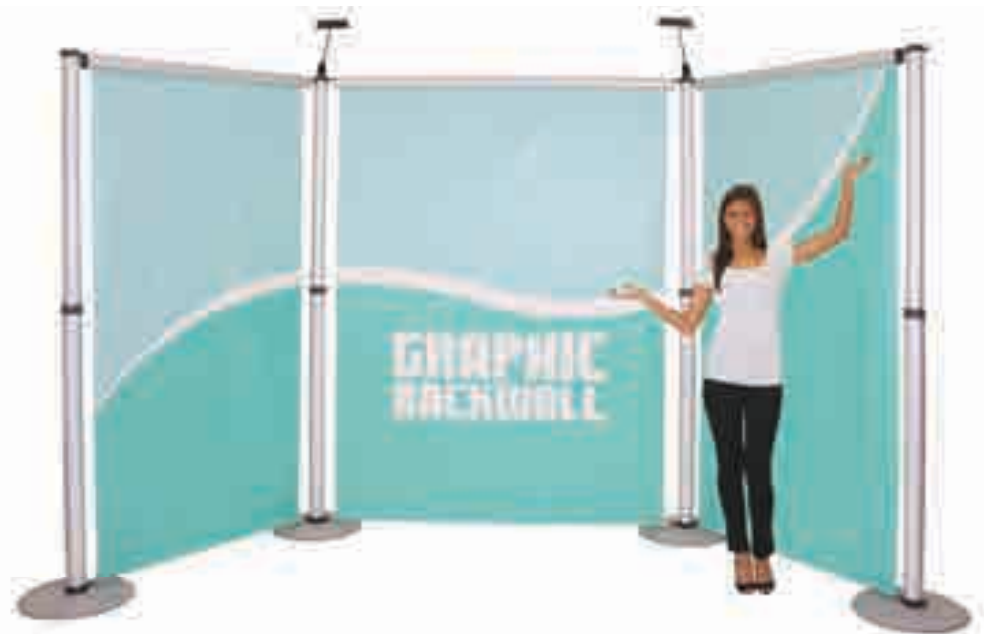

complete kit comes as shown above



shown with additional panels and lights



OBSERVE GRAND
OBG-B

- sleek info center includes sturdy base & adjustable shelf
- accepts 22" w x 28" h graphic size
- single or double sided
- holds a 3/16" thick mounted graphic



OBSERVE PRO
OBS-LP-SYS

- lightweight snap together info center
- 12" diameter base
- stylish curved header
- adjustable brochure holder
- accepts 8.5" w x 11" h graphic and literature
- molded sign clamp will hold an 1/8" thick mounted graphic



VECTOR FRAMES

- easy to set up and break down
- clean, simple, sophisticated look
- vibrant tension fabric graphic
- extrusion based
- single or double sided
- heavy duty silver frame & feet
- custom sizes available



AVAILABLE SIZES:



01 Rectangle
VF-R-01
35" w x 47" h
comes in 1 OCL case



02 Rectangle
VF-R-02
35" w x 70" h
comes in 1 OCS case



03 Rectangle
VF-R-03
47" w x 70" h
comes in 1 OCL case



04 Rectangle
VF-R-04
47" w x 94" h
comes in 1 OCL case



01 Square
VF-S-01
35" w x 35" h
comes in 1 OCS case



02 Square
VF-S-02
47" w x 47" h
comes in 1 OCL case



03 Square
VF-S-03
70" w x 70" h
comes in 1 OCS case



04 Square
VF-S-04
94" w x 94" h
comes in 1 OCL case



VECTOR FRAME WALL BRACKET

VF-BRKT-4

- supports any size vector frame
- quick and easy to assemble
- turns your vector frame from a portable to a wall display
- customer to provide fasteners
- sold in packs of four



OCS

OCL

VECTOR FRAME KITS



counter tops are available in your choice of finishes

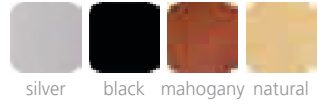

Stand apart from the competition with a clean, sophisticated 10'x10' or 10'x20' Vector Frame exhibit kit. The Vector Frame series is a collection of extrusion-based, dye-sublimated fabric mural graphic displays. Vector Frame exhibits are easy to assemble and disassemble.





KIT 05
VF-K-05



KIT 06
VF-K-06



KIT 07
VF-K-07



KIT 08
VF-K-08



**VECTOR FRAME
COUNTER**

VFC-01

- 39.375" w x 36.625" h x 22.5" d
- four locking Vector Frames
- fabric graphics for four sides
- tops available in four finishes
- comes in 1 OCH2 case



OCH2
wheeled molded
cases included
with each kit

HOPUP BACKWALLS



Hopup tension fabric displays are simple, versatile and can be set up in seconds. Hopups feature a lightweight, heavy-duty frame that holds a durable, stretch fabric graphic mural. Simply attach the graphic, pop (expand) the frame and you have an exhibit. All curved and straight Hopups are available with and without end caps.



BACKLIT HOPUP **NEW**

- lightweight, heavy duty silver frame
- supports an integrated full fitted fabric graphic mural with end caps only
- available in 3x3 or 4x3 sizes (curved only)
- LED lights include one year limited warranty
- comes in an OCP molded case



interior lights are attached with velcro to back fabric panel



HOPUP COUNTER HOP-CT-S

- collapsible display counter
- includes black internal shelf
- hinged top available in all four laminate finishes

STRAIGHT HOPUP CONFIGURATIONS



HOP-1X1-S
approximate frame dimensions:
31" w x 31" h



HOP-2X1-S
approximate frame dimensions:
60.06" w x 31" h



HOP-2X2-S
approximate frame dimensions:
60.06" w x 60.06" h



HOP-3X2-S
approximate frame dimensions:
89.13" w x 60.06" h



HOP-1X3-S
approximate frame dimensions:
31" w x 89.13" h



HOP-2X3-S
approximate frame dimensions:
60.06" w x 89.13" h



HOP-3X3-S
approximate frame dimensions:
89.13" w x 89.13" h



HOP-4X3-S
approximate frame dimensions:
118.19" w x 89.13" h

CURVED HOPUP CONFIGURATIONS



HOP-2X1-C
approximate frame dimensions:
60.06" w x 31" h



HOP-2X2-C
approximate frame dimensions:
60.06" w x 60.06" h

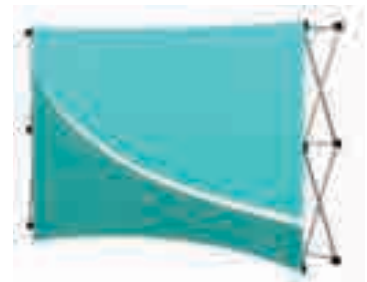

HOP-3X2-C
approximate frame dimensions:
89.13" w x 60.13" h



HOP-2X3-C
approximate frame dimensions:
60.06" w x 89.13" h



HOP-3X3-C
approximate frame dimensions:
89.13" w x 89.13" h

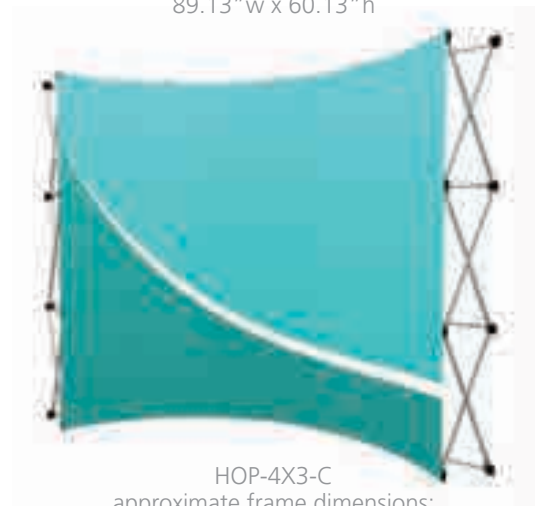

HOP-4X3-C
approximate frame dimensions:
118.19" w x 89.13" h

COYOTE POPUP



Fully magnetic popup display system provides a graphic or velcro receptive fabric backwall. Available in a wide range of size configurations. (see page 24)





OCP
OCP

- blow molded transit case
- built in wheels, handle
- light storage in the lid
- secure reinforced straps



CASE TO COUNTER CONVERSION

Roll Wrap: OCP-C2C-G

- available in fabric or graphic
- converts OCP to a counter
- polymer counter surface exposed



Stretch Wrap: OCP-SW-G

- stretch fabric pullover
- converts OCP to a counter
- polymer counter surface covered by fabric



OCP ELITE
OCP-ELITE

- heavy duty shipping and storage case
- lid can be used as a step stool
- access door provides storage when unit is used as a counter
- UPS approved



CASE TO COUNTER CONVERSION

Roll Wrap: ELITE-C2C-G

- available in fabric or graphic
- converts OCP Elite to a counter
- counter surface exposed



Stretch Wrap: ELITE-SW-G

- stretch fabric pullover
- converts OCP Elite to a counter
- counter surface covered by fabric

FABRIC CHOICES

All Coyote popup display systems are available with printed graphic murals or "velcro-friendly" fabric panels of your choice. Actual fabric color may vary slightly.

regal - smooth exhibit & display fabric

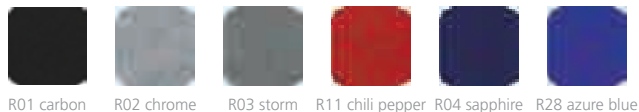

premier - ribbed exhibit & display fabric



All molded Cases have a one year hardware warranty and are an eco-friendly choice.

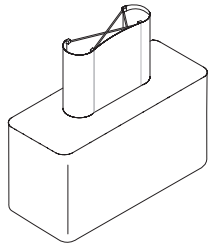

4' tabletop
footprint dimensions:
45.5" w x 30.625" h x 12.5" d

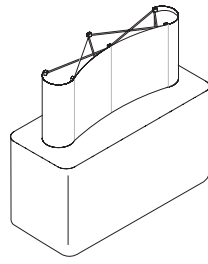

6' tabletop
footprint dimensions:
73" w x 30.625" h x 19.25" d

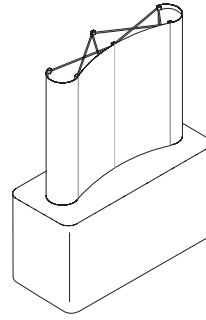

6' tabletop
footprint dimensions:
73" w x 59.375" h x 19.25" d

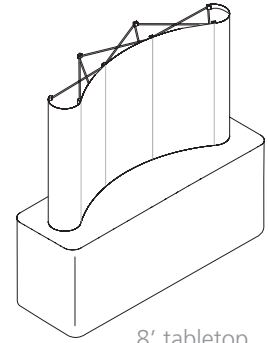

8' tabletop
footprint dimensions:
97.25" w x 59.375" h x 25" d

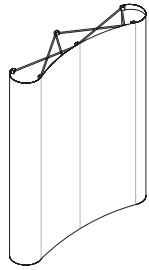

6' full height
slim-line display system
footprint dimensions:
73" w x 87.56" h x 19.25" d

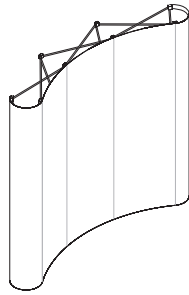

8' full height
standard display system
footprint dimensions:
97.25" w x 87.56" h x 25" d

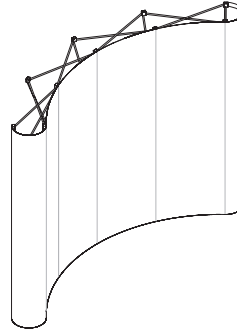

10' full height
standard display system
footprint dimensions:
118" w x 87.56" h x 36.5" d

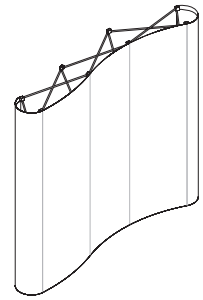

8' serpentine
full height display system
footprint dimensions:
89.5" w x 87.56" h x 19.5" d

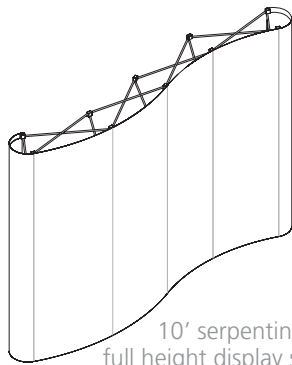

10' serpentine
full height display system
footprint dimensions:
129.5" w x 87.56" h x 19.5" d

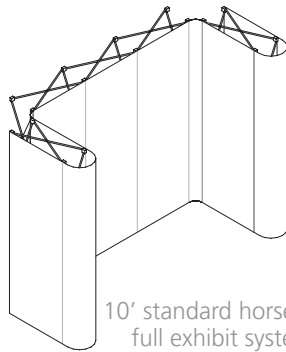

10' standard horseshoe
full exhibit system
footprint dimensions:
113" w x 87.56" h x 54" d

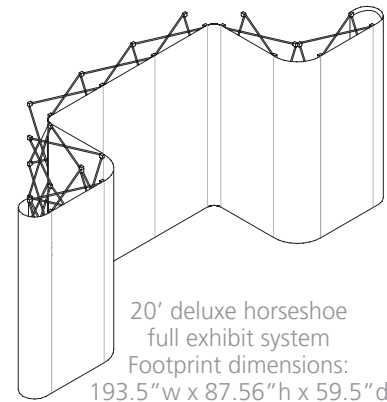

20' deluxe horseshoe
full exhibit system
Footprint dimensions:
193.5" w x 87.56" h x 59.5" d



20' gullwing full trade show
exhibit system
footprint dimensions:
231" w x 87.56" h x 41" d

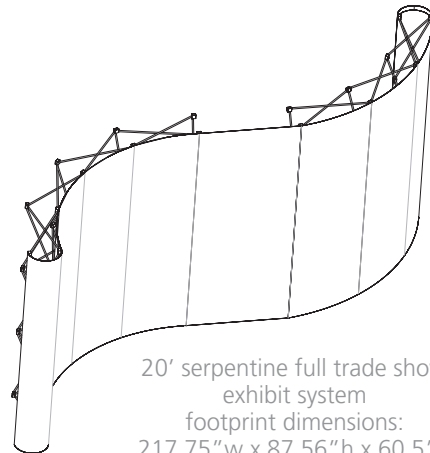

20' serpentine full trade show
exhibit system
footprint dimensions:
217.75" w x 87.56" h x 60.5" d

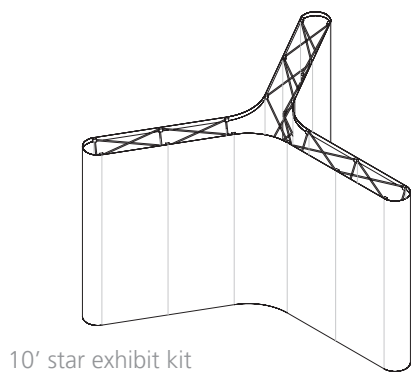

10' star exhibit kit

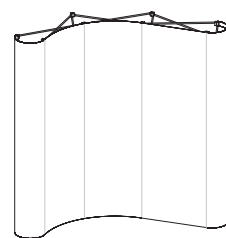
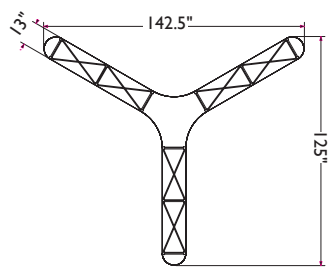

8' "L" exhibit kit

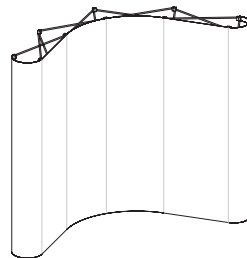
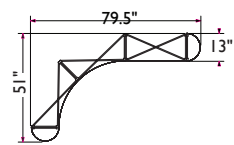

10' small "L" exhibit kit

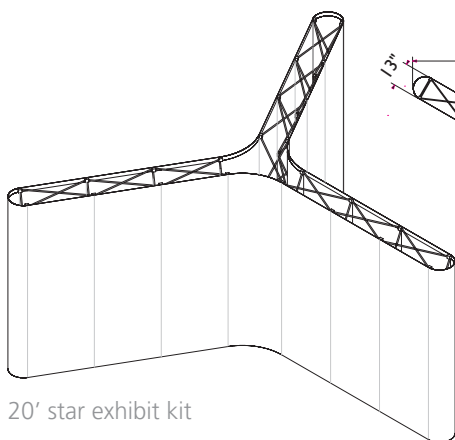
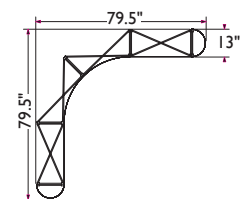

20' star exhibit kit

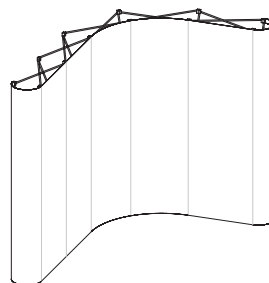
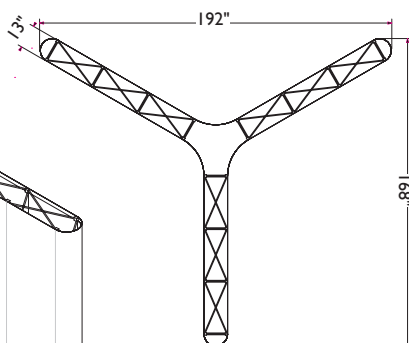

10' large "L" exhibit kit

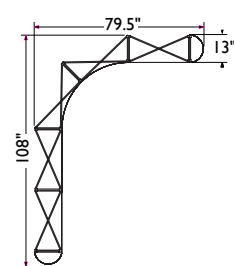

3x2 mini tabletop kit
footprint dimensions:
74.625" w x 48" h x 15.75" d

COYOTE MINI

- approx. 20% smaller than standard Coyote tabletops
- entire display rolls up into special storage sleeve which slides into a padded carry case
- kit includes frame, channel bars, panel hangers, carry case, & 2 lights
- add an optional OCS hard case for shipping or extra secure storage



2x2 mini tabletop kit
footprint dimensions:
53.625" w x 48" h x 11.75" d





COYOTE OPTIONS

Customize your Coyote display with a variety of optional accessories.

COYOTE ACCENT KIT

COY-ACCT-K

- a fresh new look for your Coyote popup
- update your current display with 2 modern wing shapes and 4 extrusions



MONITOR MOUNT

- fully integrates with straight or curved Coyote systems
- one panel cut to fit the monitor
- VESA bolt compatible
- max weight= 50lbs
- LCD max size = 23"



not recommended for plasma or CRT units



INTERNAL SHELF KIT

- presents products or literature
- comes with 2 clear acrylic shelves to be used horizontally or at 45° angles
- max capacity per shelf = 15 lbs, max per quadrant = 45 lbs
- for use with curved frame only
- lighting package available (not to be stored with display in OCP)



COYOTE TOWER

COY-3-G-TOW

- an unexpected addition to any display; large or small, exhibit or P.O.P.
- back-lit panels illuminate your graphics
- coordinates with the look and style of your Coyote popup display



BUBBLE PANEL

- forward facing, convex panel
- panel can be fabric, opaque graphic or rear illuminated graphic (light kit sold separately)
- hardware can be stored with display in OCP

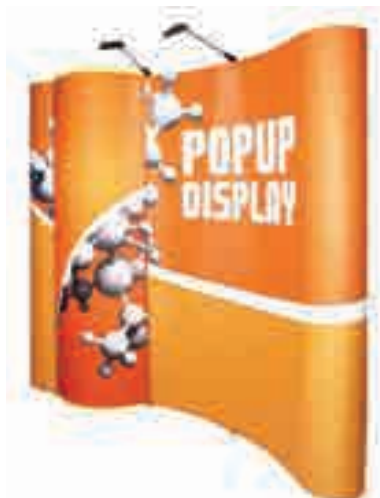

OCP case is a blow molded transit case with built in wheels, handle, and light storage in the lid.



Lumina 200 & Lumina 7 are excellent lighting solutions for your Coyote popup exhibit. (see page 72)





FORMULATE TENSION FABRIC

Formulate backwalls are advanced aluminum structures with fabric graphics. Some kits include: front curved accents, low voltage lighting, tabletops and/or counter, literature pockets, headers and top accents. All kits come in hard molded transport case(s).



FORMULATE | TENSION FABRIC

FORMULATE TABLETOP



Formulate TT1
FMLT-WTT-V01



Formulate TT2
FMLT-WTT-V02



Formulate TT3
FMLT-WTT-V03

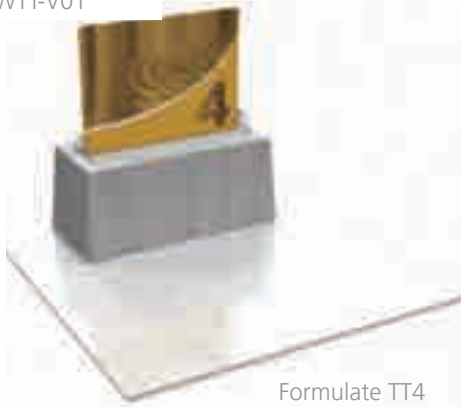

Formulate TT4
FMLT-WTT-S01

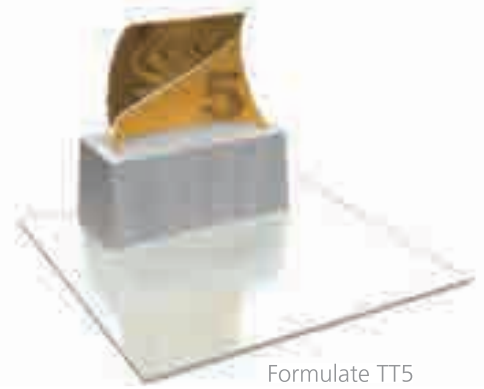

Formulate TT5
FMLT-WTT-S02

10' FORMULATE STRAIGHT



Formulate S1
FMLT-WS10-01



Formulate S2
FMLT-WS10-02



Formulate S3
FMLT-WS10-03



Formulate S4
FMLT-WS10-04



Formulate S5
FMLT-WS10-05

10' FORMULATE HORIZONTALLY CURVED



Formulate HC1
FMLT-WH10-01



Formulate HC2
FMLT-WH10-02

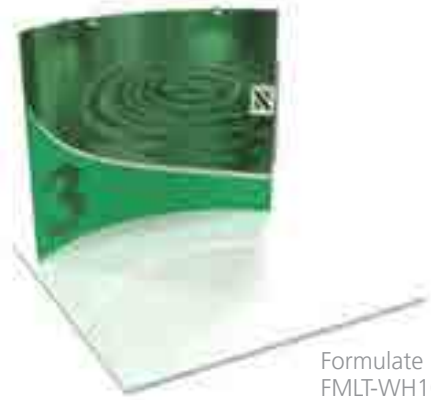

Formulate HC3
FMLT-WH10-03



Formulate HC4
FMLT-WH10-04

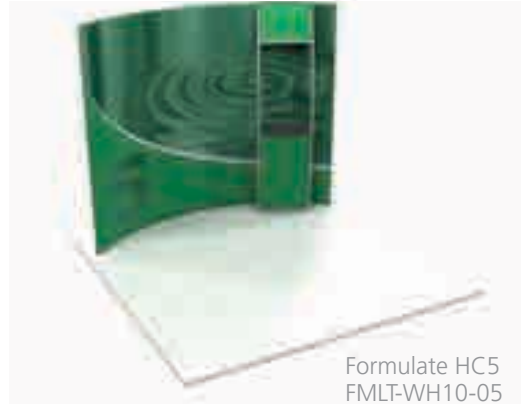

Formulate HC5
FMLT-WH10-05

10' FORMULATE VERTICALLY CURVED

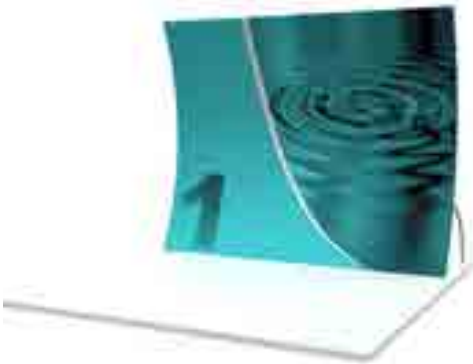

Formulate VC1
FMLT-WV10-01

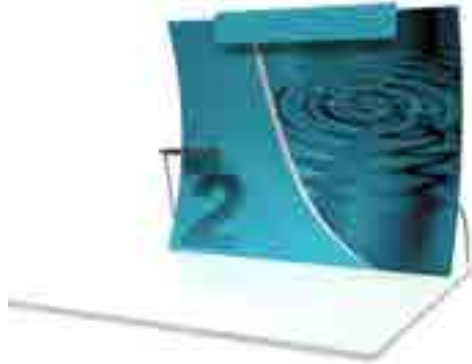

Formulate VC2
FMLT-WV10-02



Formulate VC3
FMLT-WV10-03



Formulate VC4
FMLT-WV10-04



Formulate VC5
FMLT-WV10-05



Formulate VC6
FMLT-WV10-06



All Formulate structures come with a lifetime hardware warranty.

8' FORMULATE BACKWALLS



Formulate 8S
FMLT-WS8-01



Formulate 8H
FMLT-WH8-01



Formulate 8V
FMLT-WV8-01

20' FORMULATE BACKWALLS



Formulate 20 Straight
FMLT-WS20-01

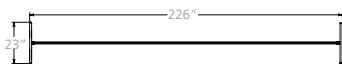

Formulate 20S
FMLT-WSC20-01



Formulate 20H
FMLT-WH20-01

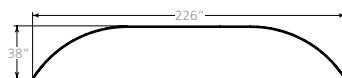

Formulate 20V
FMLT-WV20-01



FORMULATE HANGING STRUCTURES

RING

- 8' diam. x 3'h
- 10'9" diam. x 4'h
- 12' diam. x 4'h
- 14' diam. x 4'h
- 16' diam. x 4'h
- 18' diam. x 4'h
- 20' diam. x 4'h

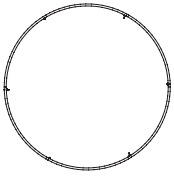

TAPERED RING

- 8' diam. x 3'h
- 10'9" diam. x 4'h
- 12' diam. x 4'h
- 14' diam. x 4'h
- 16' diam. x 4'h
- 18' diam. x 4'h
- 20' diam. x 4'h

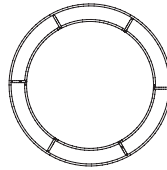

FOUR SIDED

- 6'w x 3'h
- 8'w x 3'h
- 8'10"w x 4'h
- 12'w x 4'h
- 14'w x 4'h
- 16'w x 4'h
- 18'w x 4'h
- 20'w x 4'h

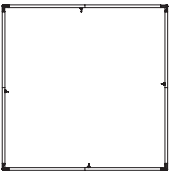

TAPERED FOUR SIDED

- 10'w x 4'h
- 12'w x 4'h
- 16'w x 5'h
- 20'w x 5'h

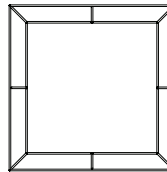

CONCAVE FOUR SIDED

- 8'10"w x 3'h
- 8'10"w x 4'h
- 12'w x 4'h
- 14'w x 4'h
- 16'w x 4'h
- 18'w x 4'h
- 20'w x 4'h



THREE SIDED

- 6'w x 3'h
- 8'10"w x 4'h
- 10'w x 4'h
- 12'w x 4'h
- 14'w x 4'h
- 16'w x 4'h
- 18'w x 4'h
- 20'w x 4'h

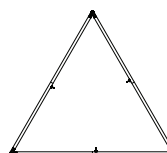

All Formulate structures come with hanging hardware and a lifetime hardware warranty. Cases available upon request. Custom sizes also available.

TAPERED THREE SIDED

- 10'w x 4'h
- 12'w x 4'h
- 16'w x 5'h
- 20'w x 5'h

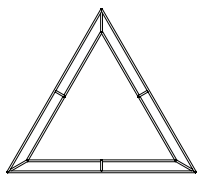

CONVEX THREE SIDED

- 8'9" w x 3' h
- 8'9" w x 4' h
- 12' w x 4' h
- 15' w x 4' h
- 20' w x 5' h

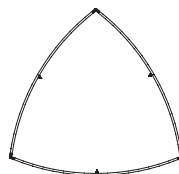

PINWHEEL

- 8'9" w x 3' h
- 8'9" w x 4' h
- 12' w x 4' h
- 16' w x 4' h
- 20' w x 4' h
- 20' w x 5' h



RECTANGLE

- 12' l x 6' w x 4' h
- 16' l x 8' w x 5' h
- 20' l x 10' w x 5' h

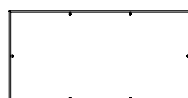

FOOTBALL

- 8'9" l x 3' h
- 8'9" l x 4' h
- 12' l x 4' h
- 15' l x 4' h
- 20' l x 5' h

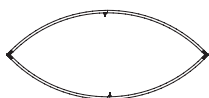

FOUR SIDED PYRAMID

- 10' w x 5' h
- 12' w x 6' h
- 16' w x 8' h
- 20' w x 10' h

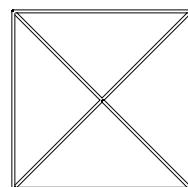

THREE SIDED PYRAMID

- 10'w x 5'h
- 12'w x 6'h
- 16'w x 8'h
- 20'w x 10'h

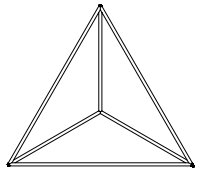

ROUND FUNNEL

- 10'w x 4'h

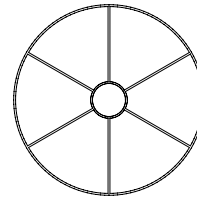

SQUARE FUNNEL

- 10'w x 4'h

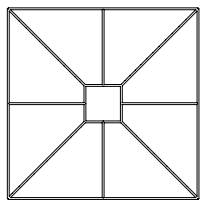

CONE

- 10'w x 5'h
- 12'w x 6'h
- 16'w x 8'h
- 20'w x 10'h

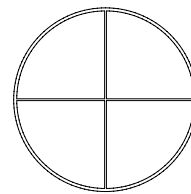

CURVE

- 8'w x 3'h
- 8'9" w x 4'h
- 12'w x 4'h
- 15'w x 4'h
- 16'w x 4'h
- 20'w x 4'h
- 20'w x 6'h

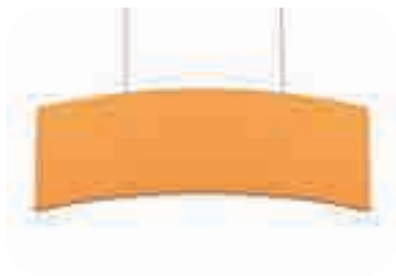

PANEL

- 6'w x 3'h
- 8'w x 3'h
- 8'9" w x 4'h
- 12'w x 4'h
- 15'w x 4'h
- 16'w x 4'h
- 20'w x 4'h
- 20'w x 6'h

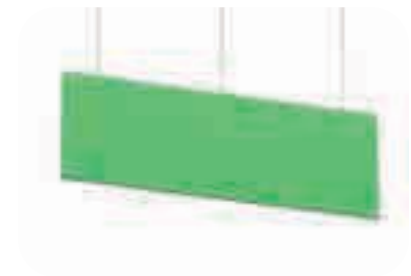

DISC

- 8' diameter
- 10'9" diameter
- 12' diameter
- 14' diameter
- 16' diameter
- 18' diameter
- 20' diameter



S-CURVE

- 8'w x 3'h
- 12'w x 4'h
- 12'w x 6'h
- 15'6" w x 4'h
- 16'w x 4'h
- 16'w x 6'h
- 20'w x 6'h



All Formulate structures come with hanging hardware and a lifetime hardware warranty. Cases available upon request. Custom sizes also available.

VIBE



Vibe is a collection of cleverly-designed state-of-the-art 10' exhibit booths. Vibe combines light-weight aluminum structures with pillowcase dye-sublimated printed fabric graphics for a truly unique appearance and experience.

VIBE | TENSION FABRIC



KIT 01
VBK-1

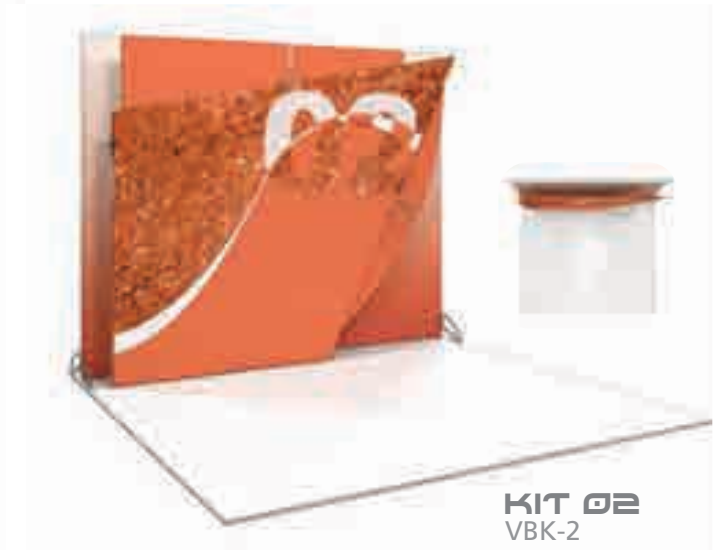

KIT 02
VBK-2



KIT 03
VBK-3

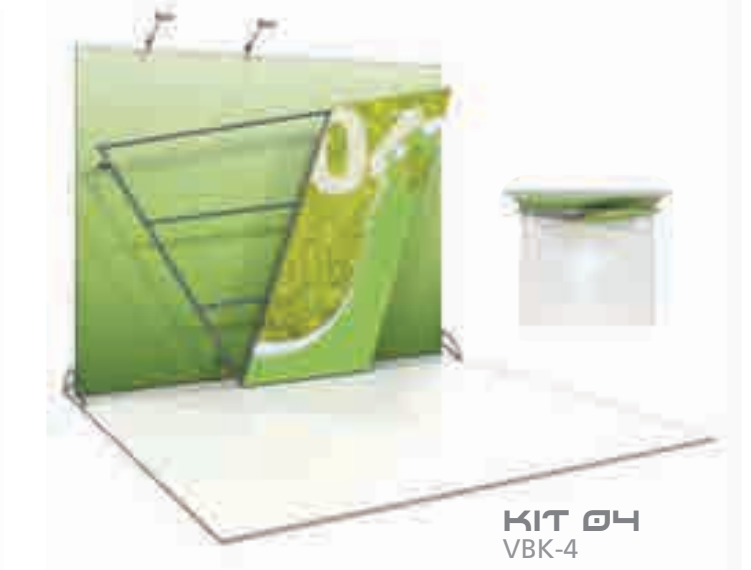

KIT 04
VBK-4

Vibe is a collection of cleverly-designed state-of-the-art 10' exhibit booths. Vibe combines light-weight aluminum structures with pillowcase dye-sublimated printed fabric graphics for a truly unique appearance and experience.

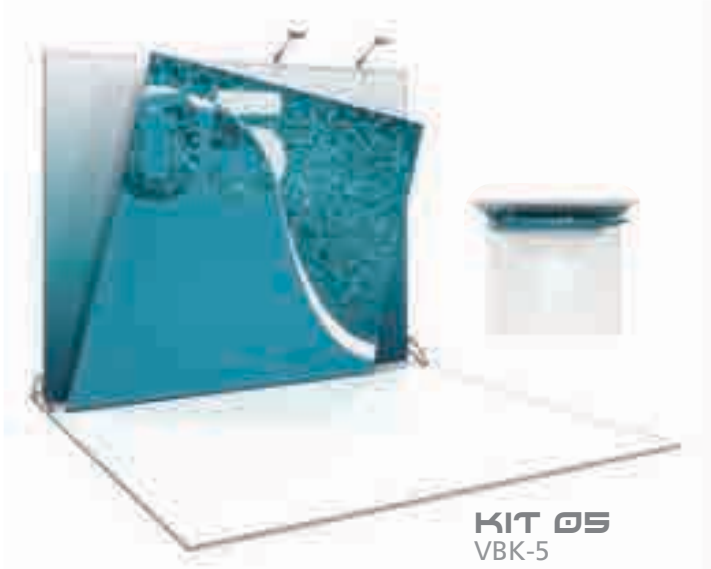

Vibe counter tops are available in your choice of four thermoform finishes

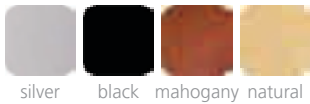

silver black mahogany natural

Vibe counter bases are available in your choice of four laminate options

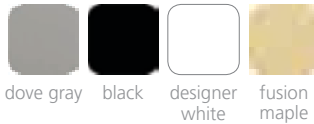

dove gray black designer white fusion maple



VIBE COUNTER 01
VB-01

- 64" w x 40" h x 20" d
- approx. weight with OCH2 case: 120 lbs
- custom colors available upon request



VIBE COUNTER 02
VB-02

- 46" w x 40" h x 20" d
- approx. weight with OCH2 case: 120 lbs
- custom colors available upon request



VIBE COUNTER 03
VB-03

- 46" w x 40" h x 20" d
- approx. weight with OCH2 case: 120 lbs
- custom colors available upon request



VIBE MONITOR KIOSK
VB-MK-01

- metal structure
- medium monitor bracket, max weight: 50 lbs (monitor not included)
- OCH2 case

TABLE THROW

- 4' full: TBL-T-4-F
- 4' economy: TBL-T-4-E
- 6' full: TBL-T-6-F
- 6' economy: TBL-T-6-E
- 8' full: TBL-T-8-F
- 8' economy: TBL-T-8-E

- complete your presentation with a premium printed table throw
- lends a polished appearance to any display
- maximize your advertising with additional space to display your message



shown with Horizon Standard tabletop folding panel display (see page 38)



4' table throws now available for smaller tables

TABLE RUNNERS

- 24" full: TBL-R-24-F
- 24" economy: TBL-R-24-E
- 30" full: TBL-R-30-F
- 30" economy: TBL-R-30-E
- 60" full: TBL-R-60-F
- 60" economy: TBL-R-60-E

- accent your solid colored table throw with a full color printed runner
- available in 3 widths



CONVERTIBLE TABLE THROW

- convertible full: TBL-T-FC
- convertible economy: TBL-T-EC

- converts quickly and easily to fit both a 6' and 8' table
- Velcro tabs make conversion simple



IMPRINTED TABLE THROW

- 6' full
- 6' economy
- 8' full
- 8' economy

- 11 standard tablethrow colors
- maximum logo size = 60" w x 21.5" h (see template for details)
- must be simple vector artwork, no complex logos or gradients
- referenced Pantone colors are not exact



carry bag available
TBL-THRW-BG



full table throw shown in white fabric with blue and sapphire imprinted vinyl



economy table throw leaves back of table exposed for easy access to storage



imprinted table throw is shown with the 1 color option

ECONOMY TABLE THROW

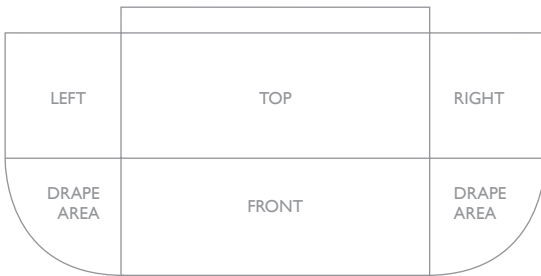

FULL TABLE THROW

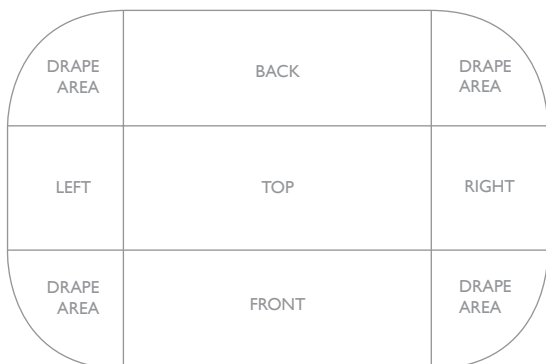

FABRIC COLORS



VINYL COLORS



All table throws and runners come with a graphic limited warranty of 6 months and are made in the U.S.A.

HORIZON



- main panel sizes approximately = 24" w x 36" h
- custom sized panel displays are available
- shown with optional detachable graphics
- available in a variety of fabric color options (page 39)



WEIGHS
22 LBS
Horizon 6
HZ-6



WEIGHS
12 LBS
Horizon 3
HZ-TT-S



WEIGHS
13.5 LBS
Horizon 5
HZ-TT-M



WEIGHS
31 LBS
Horizon 8
HZ-8

TT

black & grey: TT-D-4-BK/GRY
blue & grey: TT-D-BL/GRY

- lightweight, fabric covered tabletop display
- individual panels = 18.19" w x 22.69" h
- available in 2 front & back color combinations: black/grey, blue/grey (shown with optional graphic panels)



EFEX

2801 three panel kit:
EFX-2801
2802 three panel kit w/header:
EFX-2802

- lightweight, fabric covered tabletop display
- individual panels = 28" w x 35" h
- available in a choice of 4 basic color combinations:



EFX-2801



EFX-2802



HERO



- durable premium seamless exhibit panel kits
- convenience of folding panels with elegant, seamless panel construction
- concealed hinges
- unique 2" radius curved ends lend a polished appearance
- full height units can also be used as two tabletop units
- available in a variety of fabric color options
- shown with optional detachable graphics



fits in an OCH case
(case not included)



shown with optional graphics
HERO H16

3'11" HIGH

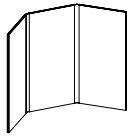

HERO H02-1
tabletop display

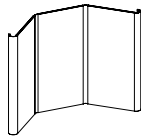

HERO H02-2
tabletop display with
curved end caps

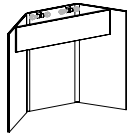

HERO H03
tabletop display with
backlit header

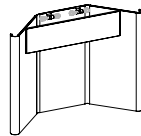

HERO H04
tabletop display with backlit
header and curved end caps

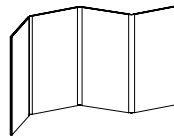

HERO H05
tabletop display

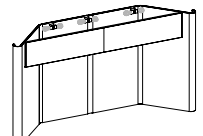

HERO H08
tabletop display with backlit
header and curved end caps

7'10" HIGH

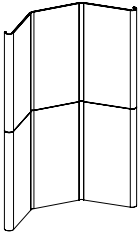

HERO H09
full height exhibit with
curved end caps

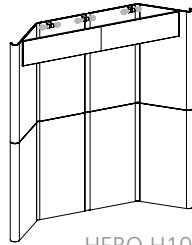

HERO H10
full height exhibit with curved
end caps and backlit header

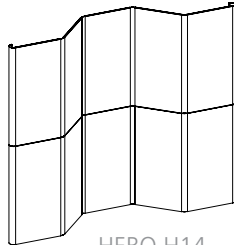

HERO H14
full height exhibit with
curved end caps

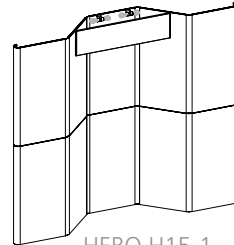

HERO H15-1
full height exhibit with
curved end caps & backlit
header

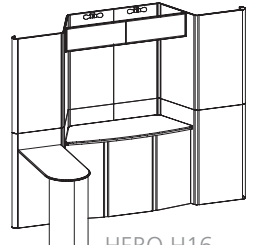

HERO H16
10' full height exhibit kit with
curved end caps, backlit
header & peninsula

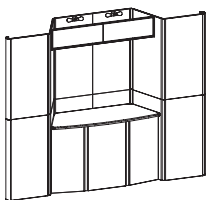

HERO H17
10' full height exhibit kit with
curved end caps & backlit header

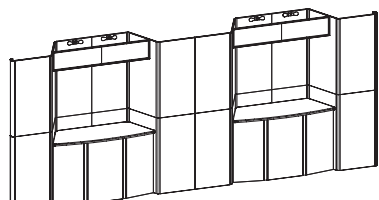

HERO H18
20' full height exhibit kit with
curved end caps & backlit header

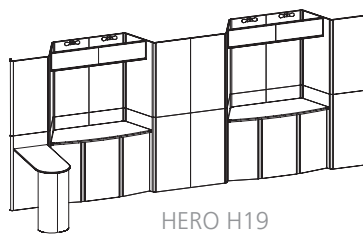

HERO H19
20' full height exhibit kit with
curved end caps, backlit header
& one peninsula

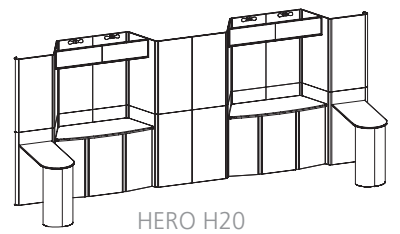

HERO H20
20' full height exhibit kit with
curved end caps, backlit header
& two peninsulas

FABRIC CHOICES

All Horizon & Hero display systems are available with printed graphic murals or "velcro-friendly" fabric panels of your choice. Actual fabric color may vary slightly.

regal - smooth exhibit & display fabric

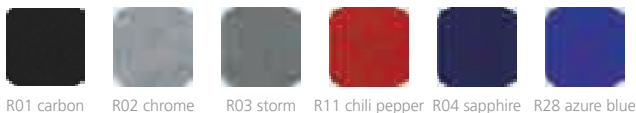

R01 carbon R02 chrome R03 storm R11 chili pepper R04 sapphire R28 azure blue

premier - ribbed exhibit & display fabric



R12 nebula R04 monarch R28 persian blue R06 indigo R31 eco green R29 beach
R30 maroon R11 electric red R02 steel R03 charcoal R15 cinder R01 lava

VOYAGER



The Voyager has been specially developed as a briefcase style table top display and is a great choice for promotions on the go. It has a rigid, thermo formed ABS exterior and a black, Velcro compatible fabric interior.

Detachable graphics allow for easy changes! Headers shown are an additional option. Extra graphics can be stored in the display case and packed away for easy storage.



WEIGHS
5 LBS **VY 1**

Voyager Mini Kit (small)
open dimensions: 48" w x 18" h
closed dimensions: 24" w x 18" h



WEIGHS
6.5 LBS **VY 2**

Voyager Maxi Kit (medium)
open dimensions: 48" w x 24" h
closed dimensions: 24" w x 24" h

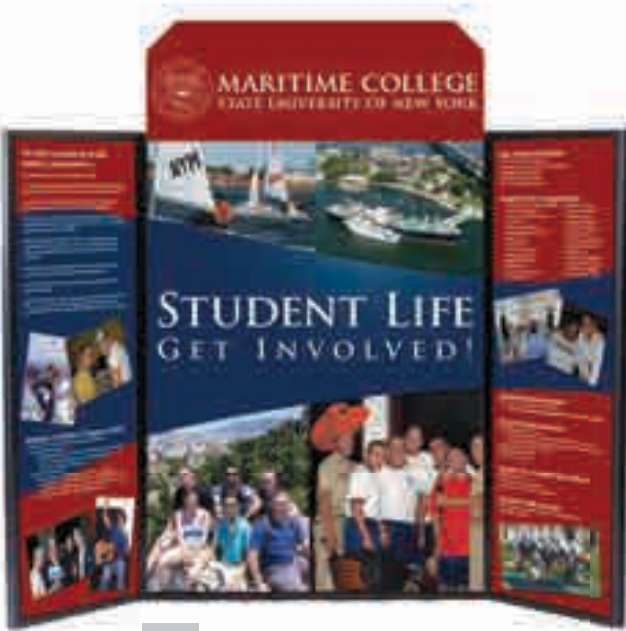

WEIGHS
8.25 LBS **VY 3**

Voyager Mega Kit (large)
open dimensions: 48" w x 32" h
closed dimensions: 24" w x 32" h



WEIGHS
8.25 LBS **VY 4**

Voyager Supreme kit (x-large)
open dimensions: 64" w x 24" h
closed dimensions: 32" w x 24" h

CUSTOMIZE

Brand the exterior of your Voyager to match your company and/or product colors to maximize your marketing efforts. Minimum 12 units, call for details.



WEIGHS
10 LBS

VY 5

Voyager Monster kit (xx-large)
open dimensions: 64" w x 32" h
closed dimensions: 32" w x 32" h



VOYAGER CARRY BAG

Voyager Mini bag:	VY-1-BG
Voyager Maxi bag:	VY-2-BG
Voyager Mega bag:	VY-3-BG
Voyager Supreme bag:	VY-4-BG
Voyager Monster bag:	VY-5-BG



ORBITAL EXPRESS TRUSS



The Orbital Express Truss System requires NO TOOLS for set up! Installation couldn't be easier, simply twist & lock. The specially designed connectors are simple to use, strong & secure. Our truss kits can be reconfigured in multiple ways using the same parts. Have a different exhibit for each show! We offer more than 60 professionally designed "off the shelf" kits for a variety of booth sizes and configurations. Each kit comes complete with all the parts, fixtures and fittings you need to create a successful exhibit, including (depending on the kit) low voltage spotlights and adjustable tabletops.



SIRIUS
10'x10'
KIT OR-K-SR1

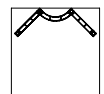

ARA

10'x10'
KIT OR-K-AA1



VELA-2

10'x10'
KIT OR-K-VL1-2



backwall
height = 72.5"



CETUS

10'x10'
KIT OR-K-CT1

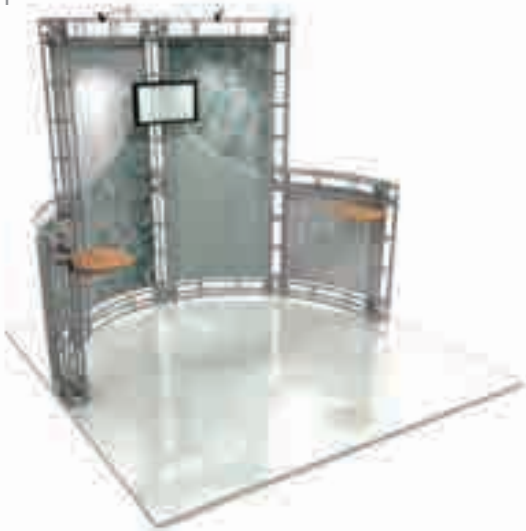

LYRA

10'x10'
KIT OR-K-LY1
corner kit



CARINA

10'x10'
KIT OR-K-CR1



CASTOR

10'x10'
KIT OR-K-CS1

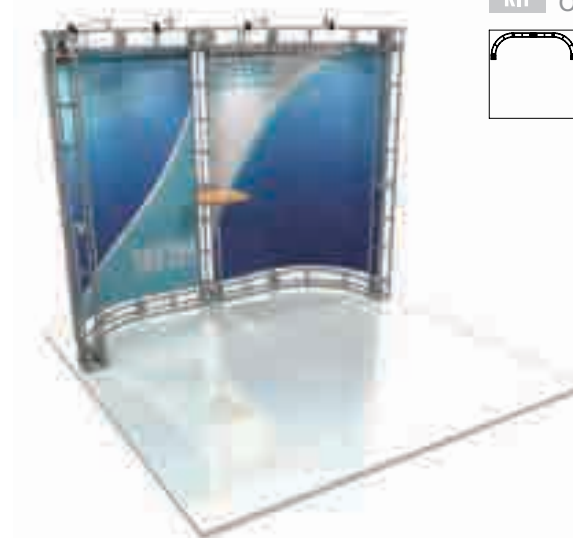

CYGNUS

10'x10' KIT OR-K-SYG2 corner kit



PLUTO

10'x10' KIT OR-K-PL1

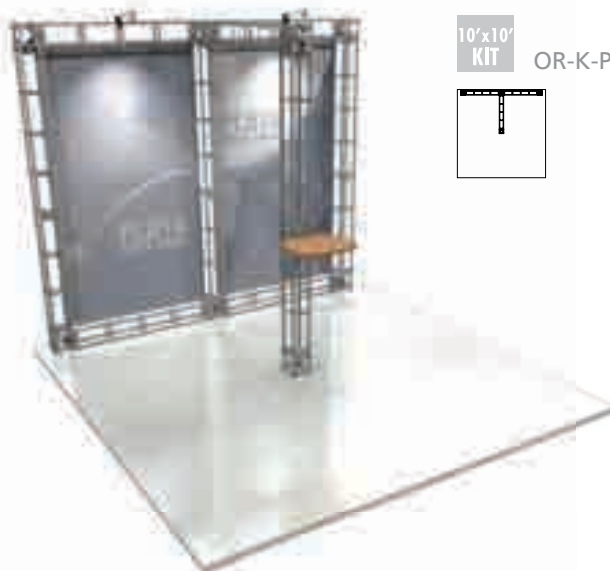

MERCURY

10'x10' KIT OR-K-ME1

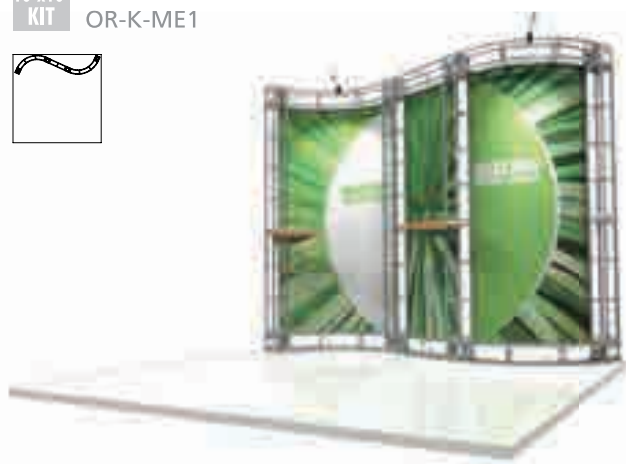

LYNX

10'x10' KIT OR-K-LX1

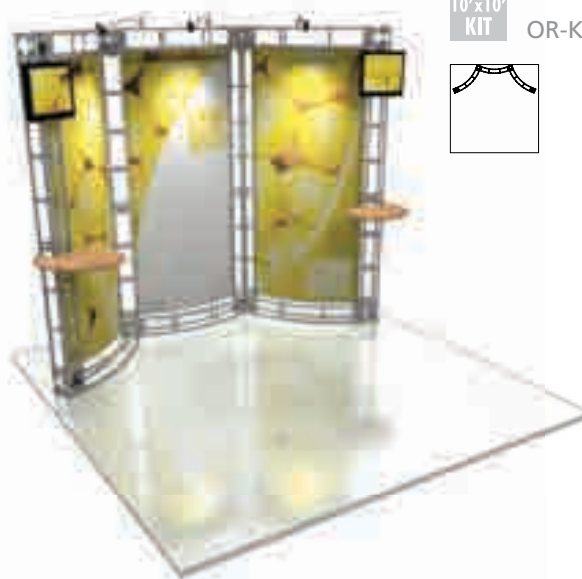

MARS

10'x10' KIT OR-K-MR1

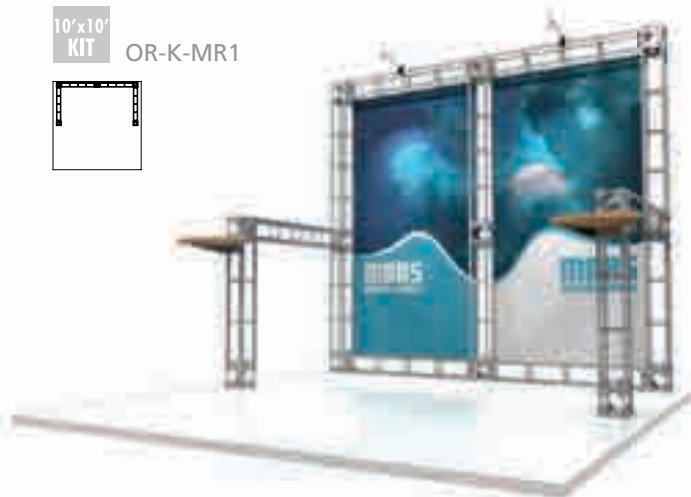

PAVO

10'x10' KIT OR-K-PA1

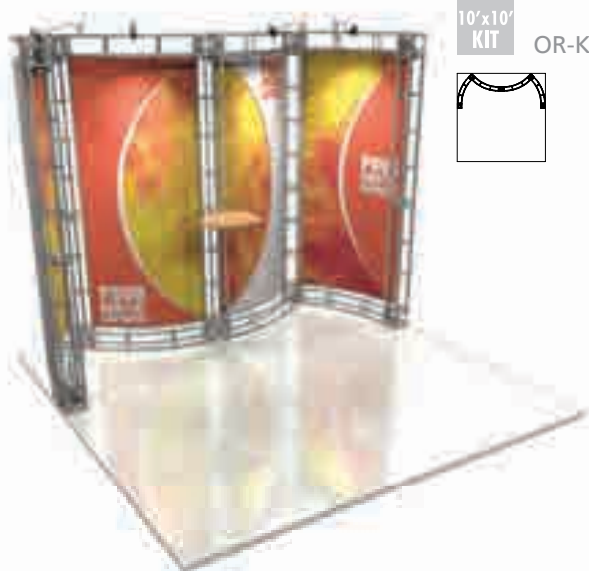

CEPHEUS-2

10'x20'
KIT

OR-K-CE1-2

backwall height = 72.5"

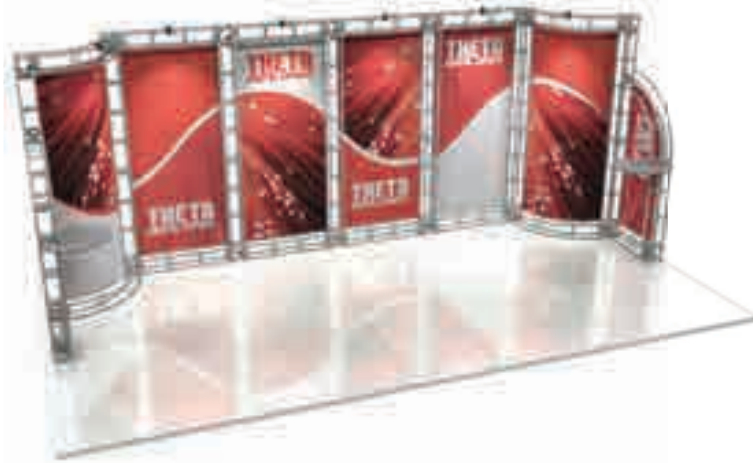
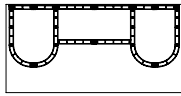

THETA

10'x20'
KIT

OR-K-TH1



PICTOR

10'x20'
KIT

OR-K-PC1

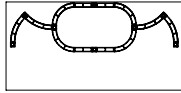

INDUS

10'x20'
KIT

OR-K-IN1

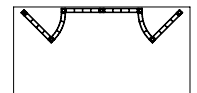

ANTARES

10'x20'
KIT

OR-K-AT1

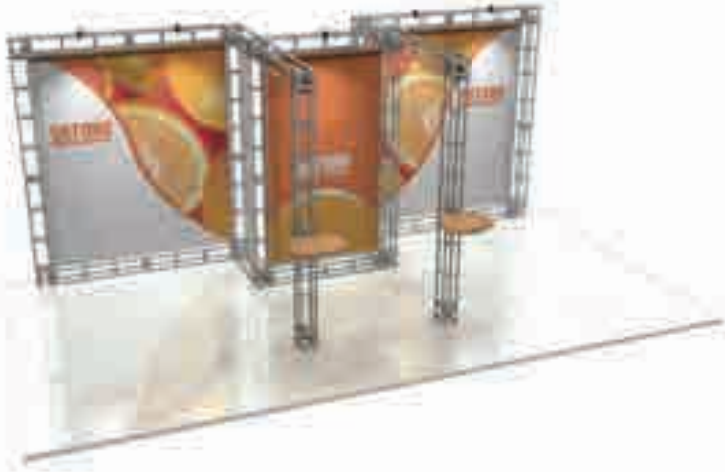
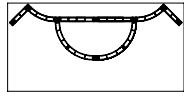

SATURN

10'x20'
KIT

OR-K-SA1

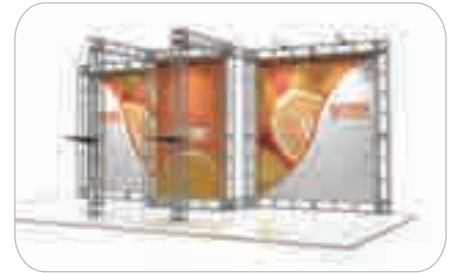
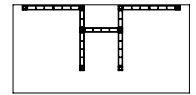

ELECTRA

10'x20'
KIT

OR-K-EL1

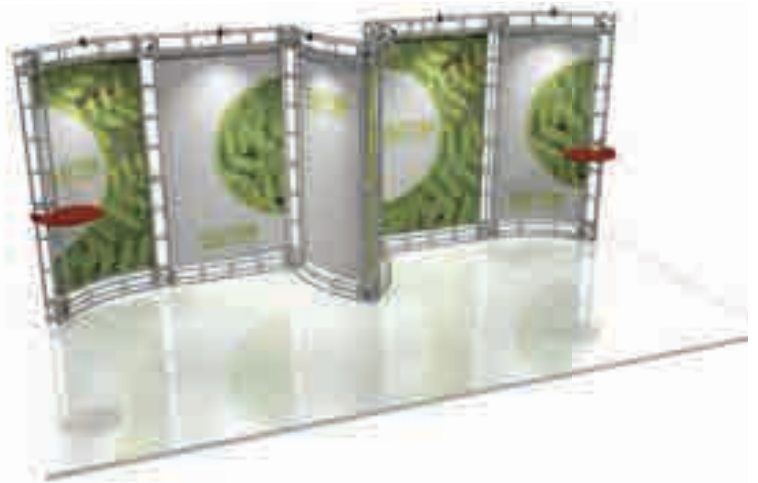
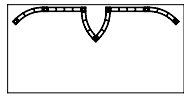

PHOENIX

10'x20'
KIT

OR-K-PX1

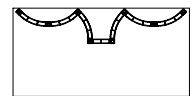

POLARIS

10' x 20'
KIT

OR-K-PR1

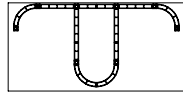

OMICRON

10' x 20'
KIT

OR-K-OM1

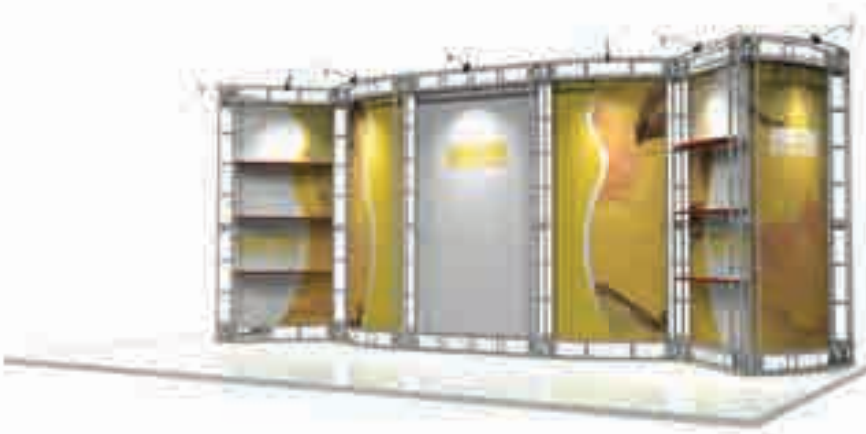
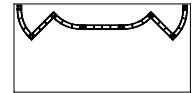

ANDROMEDA

10' x 20'
KIT

OR-K-AD1

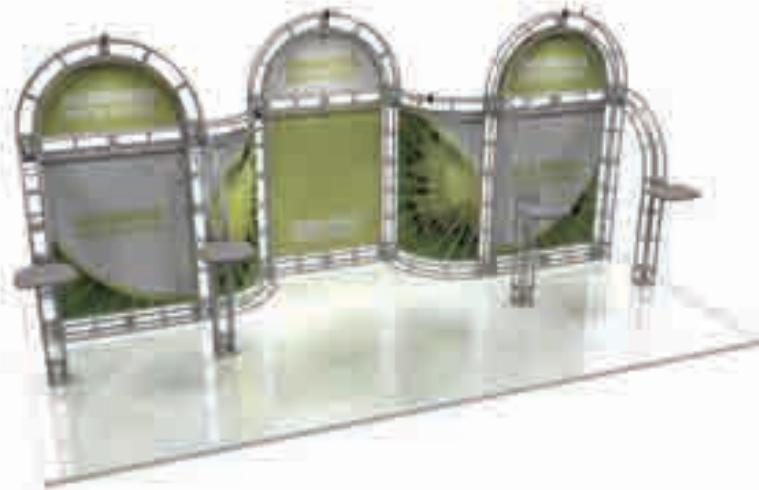
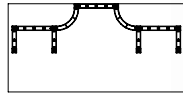

ARCTURUS

10' x 20'
KIT

OR-K-AR1

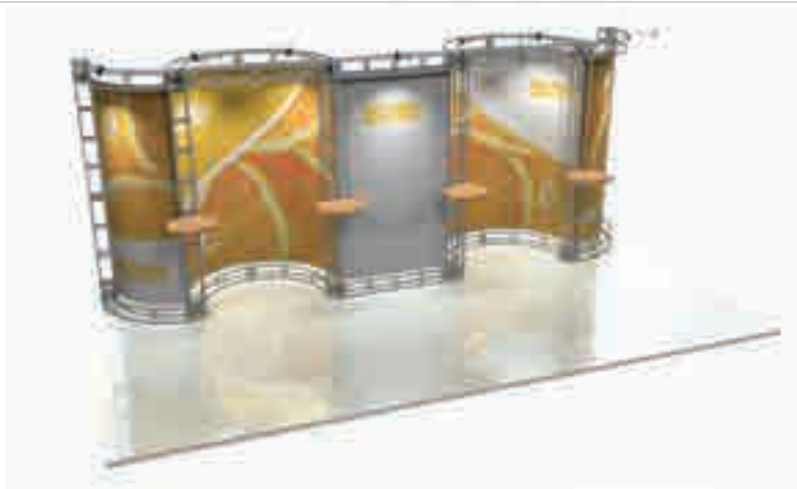
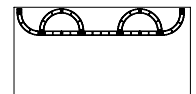

VENUS

10'x20'
KIT OR-K-VE1

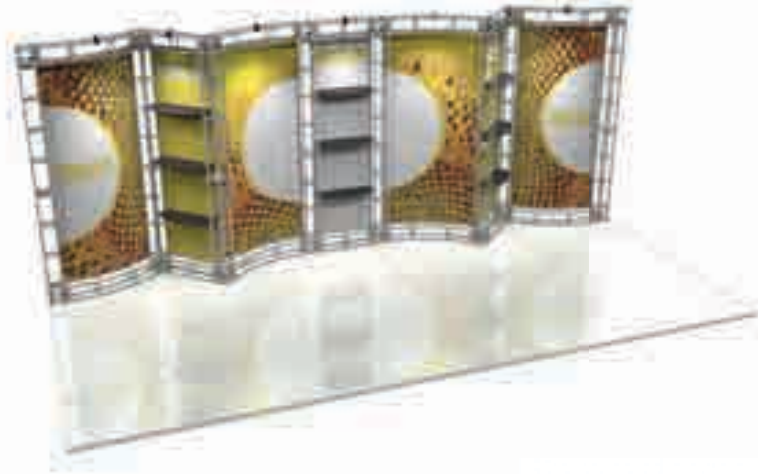
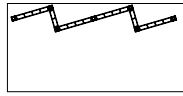

MAGELLAN

10'x20'
KIT OR-K-MG1

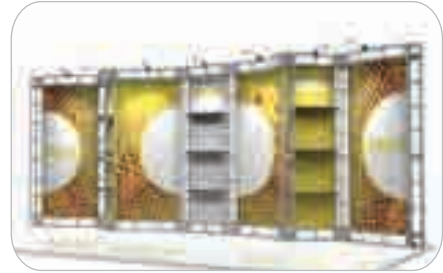
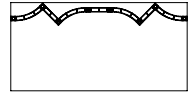

HYDRUS

10'x20'
KIT OR-K-HD1

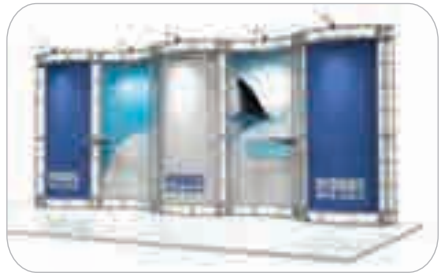
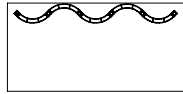

LEO

20'x20'
KIT OR-K-LE1

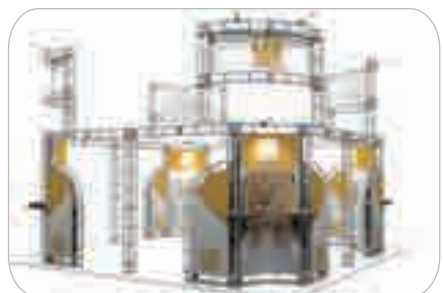
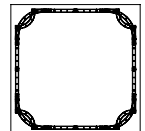

DORADO

20'x20'
KIT OR-K-DO1

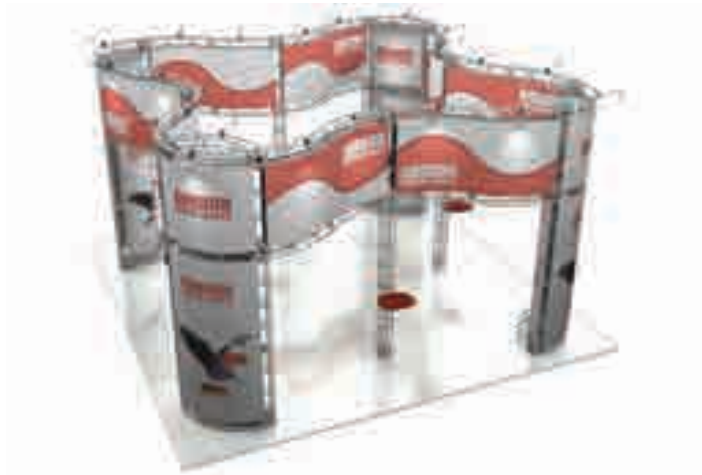
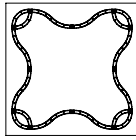

CORVUS

20'x20'
KIT OR-K-CV1

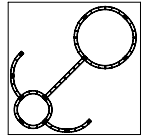

CENTAURUS

20'x20'
KIT OR-K-CN1

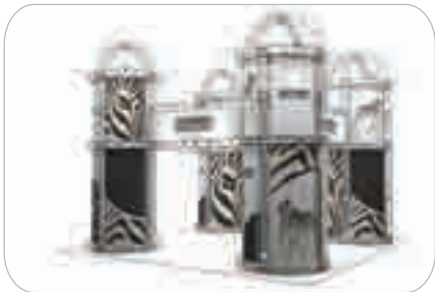
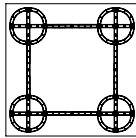

NEPTUNE

20'x20'
KIT OR-K-NP1

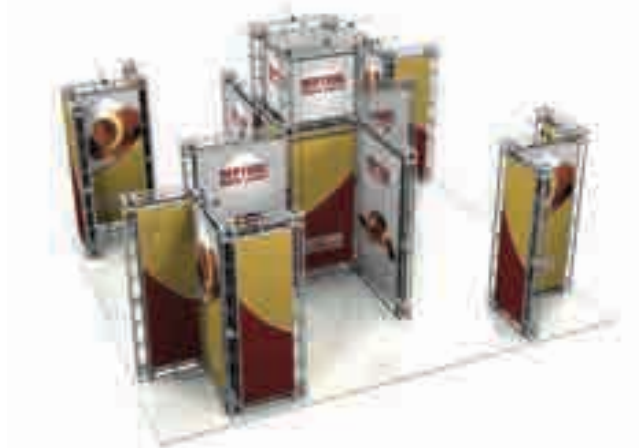
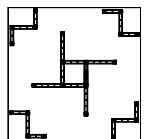

tower also sold
separately:
OR-K-NET

TUCANA

20'x20'
KIT OR-K-TU1

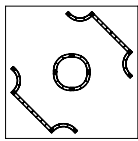

tower also sold separately: OR-K-TUT



ORION

20'x20'
KIT OR-K-OR1

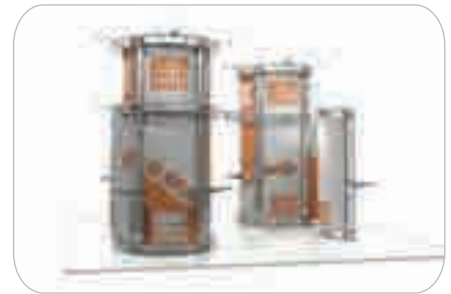
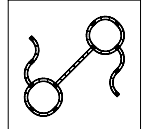

VEGA

20'x20'
KIT OR-K-VG1

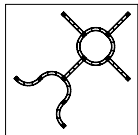

ALTAIR

20'x20'
KIT OR-K-AL1

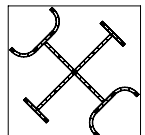



CANIS

20'x20'
KIT

OR-K-CA1

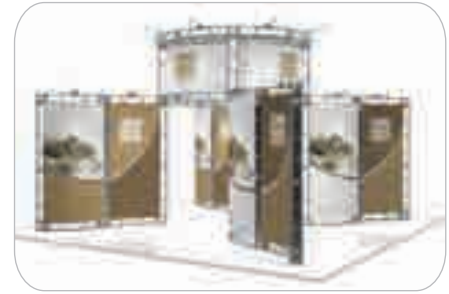
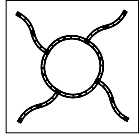

DRACO

20'x20'
KIT

OR-K-DR1

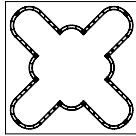

JUPITER

20'x20'
KIT

OR-K-JP1

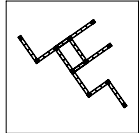

CASSIOPEIA

20'x20'
KIT

OR-K-CP1

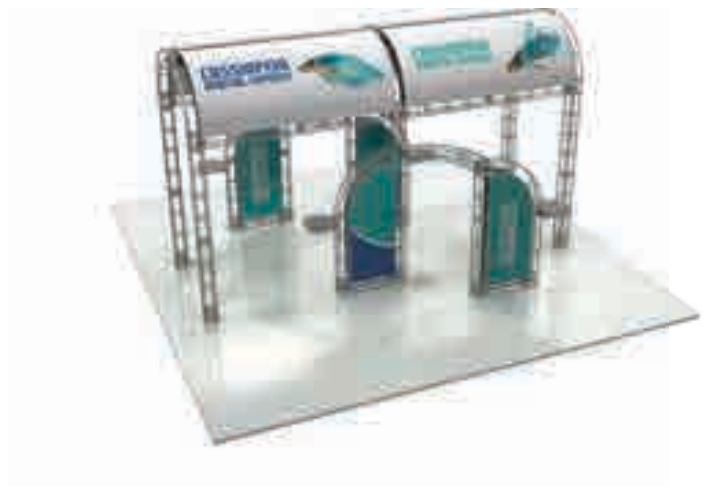
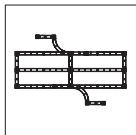

ATLANTIS

Atlantis truss backwalls offer a unique look. The shelving and monitor brackets allow for a professional looking displays. There are no tools necessary with the simple twist-lock construction. Atlantis kits are made with sturdy feet make these stand-alone backwalls possible.



Atlantis counter tops are available in your choice of four thermoform finishes

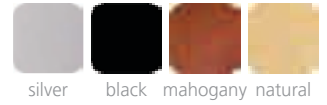

Atlantis Kit 03
OR-K-ATL3

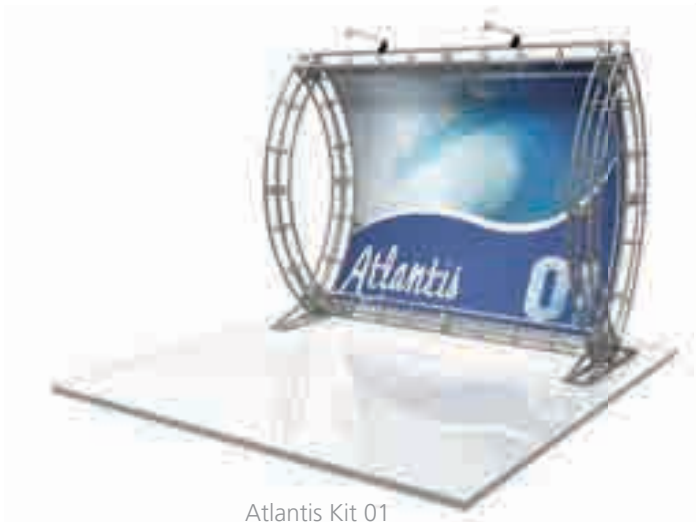

Atlantis Kit 01
OR-K-ATL1



Atlantis Kit 02
OR-K-ATL2



Atlantis Kit 04
OR-K-ATL4

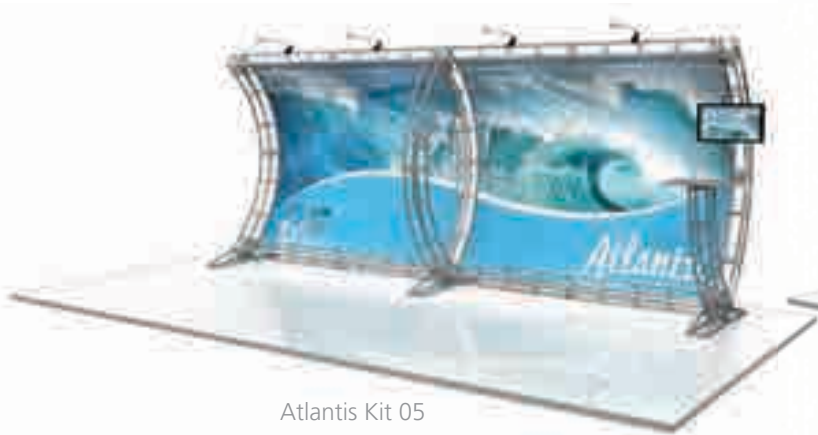

Atlantis Kit 05
OR-K-ATL5



Atlantis Kit 06
OR-K-ATL6

HERCULES



Hercules truss backwalls offer a unique look. The shelving and monitor brackets allow for a professional looking displays. There are no tools necessary with the simple twist-lock construction. Hercules kits are made with sturdy feet make these stand-alone backwalls possible.

Hercules counter tops are available in your choice of four thermoform finishes

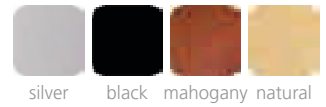

Hercules Kit 01
OR-K-HC01



Hercules Kit 02
OR-K-HC02



Hercules Kit 03
OR-K-HC03

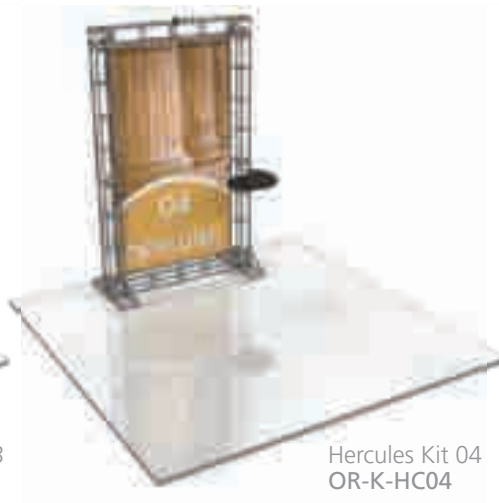

Hercules Kit 04
OR-K-HC04



Hercules Kit 05
OR-K-HC05



Hercules Kit 06
OR-K-HC06



Hercules Kit 07
OR-K-HC07

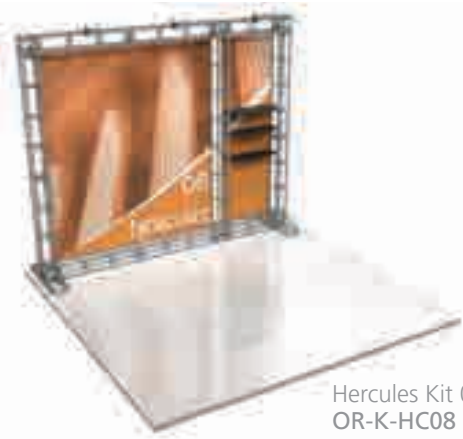

Hercules Kit 08
OR-K-HC08

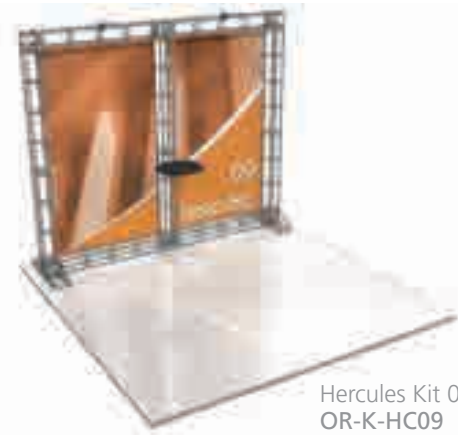

Hercules Kit 09
OR-K-HC09

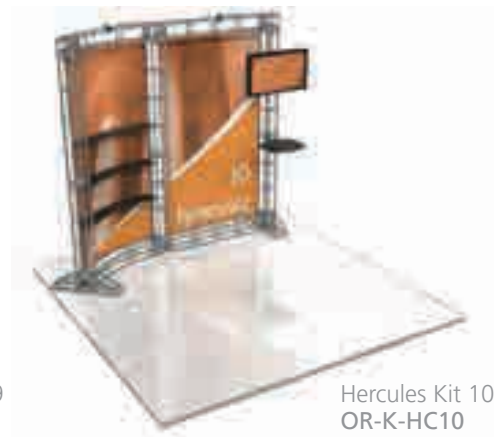

Hercules Kit 10
OR-K-HC10

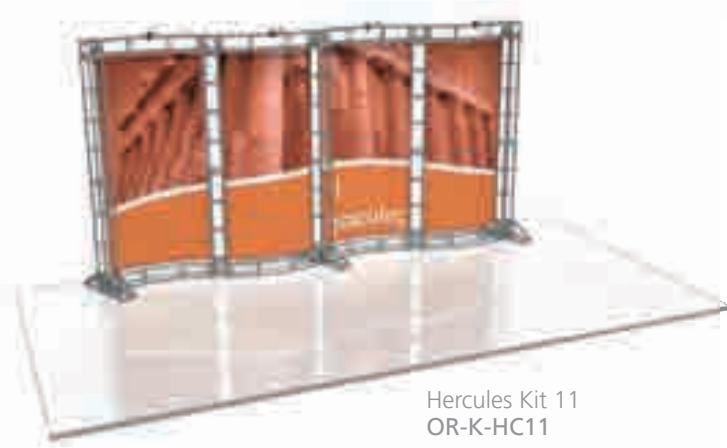

Hercules Kit 11
OR-K-HC11



Hercules Kit 12
OR-K-HC12

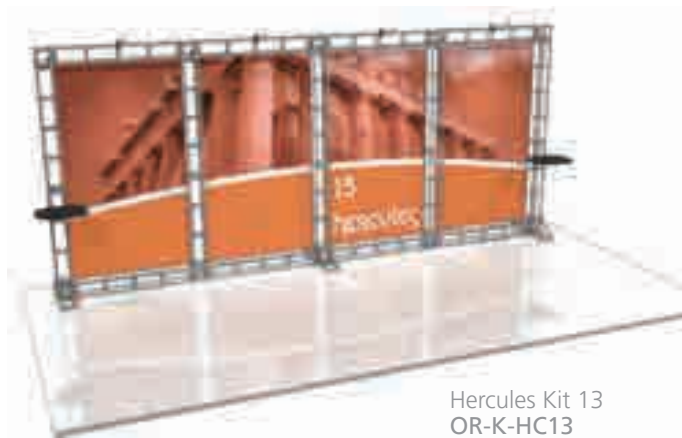

Hercules Kit 13
OR-K-HC13



Hercules Kit 14
OR-K-HC14

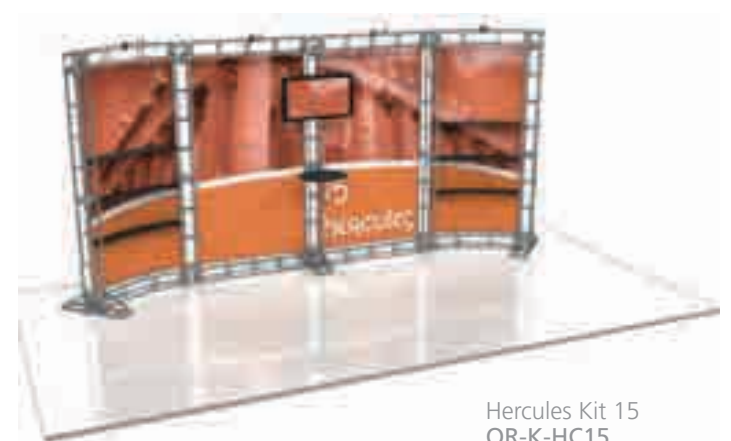

Hercules Kit 15
OR-K-HC15

ORBITAL TRUSS COUNTERS & PODIUMS

Truss Counters & Podiums have several attractive designs to choose from with a sleek plex top as an available option. Choose from 4 tabletop colors. Graphic options are also available for Truss Counters. No tools needed for assembly.



Truss counter tops are available in your choice of four thermoform finishes

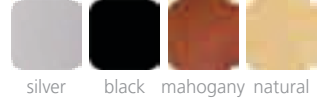

silver black mahogany natural



shown with optional front graphic panel



plex accent attaches with screw-on stand-offs

optional OCH2 case available on page 70

RECTANGLE



OR-TC01
rectangle - standard



OR-TC01-P
rectangle - with plex
stand-off and internal shelf

OVAL



OR-TC02
oval - standard



OR-TC02-P
oval - with plex stand-off
and internal shelf

RACETRACK



OR-TC03
racetrack - standard



OR-TC03-P
racetrack - with plex
stand-off and internal shelf

CURVE



OR-TC04
curve - standard



OR-TC04-P
curve - with plex stand-off
and internal shelf

CIRCLE



OR-P01
circle - standard

TEARDROP



OR-P02
teardrop - standard

EYE



OR-P03
eye - standard

RACETRACK



OR-P04
racetrack - standard

SQUARE



OR-P05
square - standard



OR-P05-P
square - shown
with optional plex

ORBITAL TRUSS ACCESSORIES

LAMINATE TABLETOPS

NATURAL



OR-TBL-WD

MAHOGANY



OR-TBL-DWD

SILVER



OR-TBL-S

BLACK



OR-TBL-B



right facing: OR-TBL2-R-WD
left facing: OR-TBL-L-WD



right facing: OR-TBL2-R-DWD
left facing: OR-TBL2-L-DWD



right facing: OR-TBL2-R-S
left facing: OR-TBL2-L-S



right facing: OR-TBL2-R-B
left facing: OR-TBL2-L-B

OPTI MOUNT

OPTI-MOUNT 1



OR-LCD1-B
13" - 27" LCD
max weight = 50 lbs

OPTI-MOUNT 2



OR-LCD2-B
26" - 42" LCD
max weight = 80 lbs

OPTI-MOUNT 3



OR-LCD3-B
30" - 50" LCD
max weight = 130 lbs

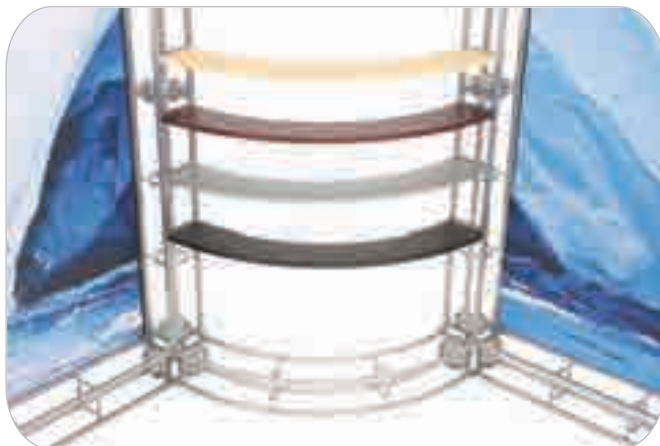

INTERNAL SHELVING

- available in all 4 finishes (light wood, mahogany, silver & black)
- 24" straight span, 36" straight span, and 46" straight span shelves available
- 45° curved and 90° curved shelves (shown above)

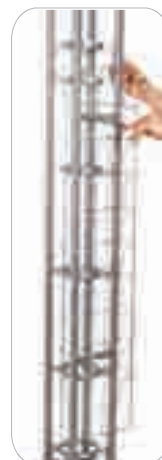

LIT RACK OR-STG



- 10 pocket clamp on literature rack
- note: rack may not fit into the standard kit packaging solution/molded case



NEW



LIFE TIME

LINEAR TABLETOP KITS

Linear Table Top Kits provide modern and dynamic flare to your marketing message. The SEG fabric graphics and extrusion-based displays are simple, lightweight and take minutes to assemble. Units come in a sturdy case. Customized units also available.



LN-K-TT-01
57" w x 31.5" h x 17.72" d

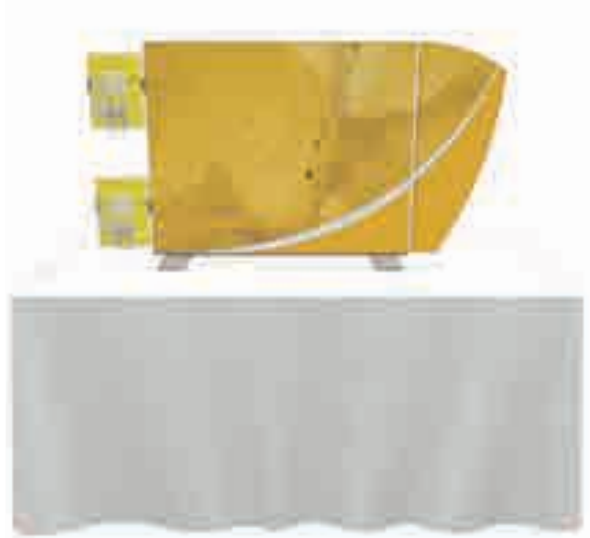

LN-K-TT-02
61.5" w x 31.5" h x 17.72" d



LN-K-TT-03
53.93" w x 39.37" h x 17.72" d



LN-K-TT-04
96" w x 39.37" h x 17.72" d



The **NEW** Linear Tabletop kits come with easy-to-apply SEG fabric graphics as well as multiple accessories.



each unit comes in a OCS sturdy case

LINEAR STANDARD

Linear Standard Kits provide a modern, slick and stylish appearance. The extrusion based exhibits feature **NEW velcro-applied fabric graphics**. Headers and wings available in UV printed graphics or frosted plex. Kits come with two lights and ship in durable storage cases. Options include LCD monitor mounts, tables, counters, literature pockets and larger freight cases. Customized units also available.



Linear counter tops are available in your choice of four thermoform finishes

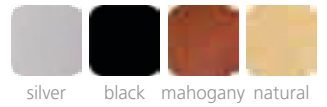

LINEAR COUNTER

LN-TBL-SA-RCT

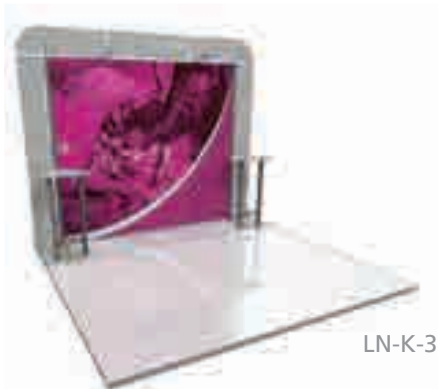

LN-K-3P-01

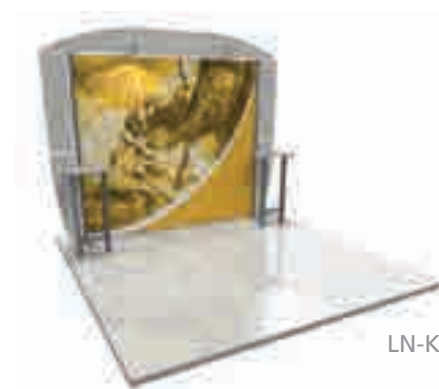

LN-K-3P-02

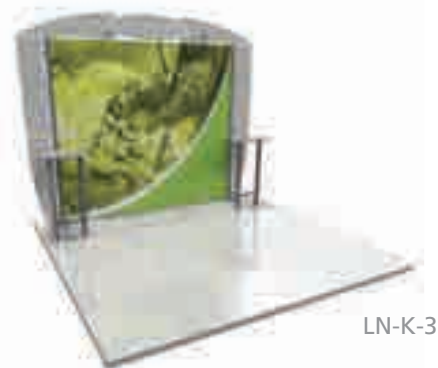

LN-K-3P-03

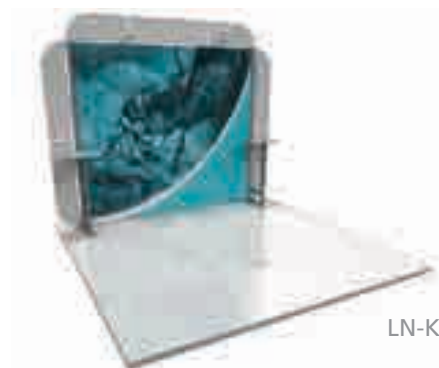

LN-K-3P-05

10'

20'



LN-K-3P-12



LN-K-3P-14

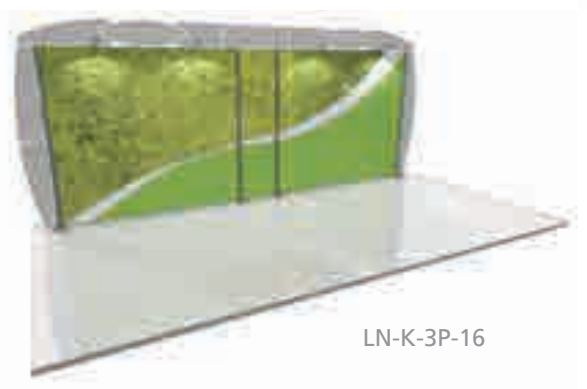

LN-K-3P-16

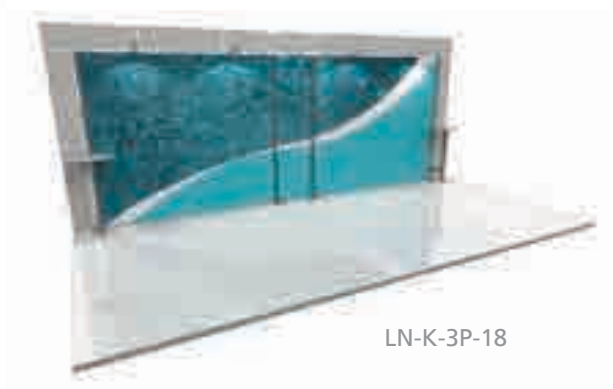

LN-K-3P-18



OCH



LINEAR PRO

Linear Pro Kits provide a modern, slick and stylish appearance. The extrusion based exhibits feature **NEW velcro-applied fabric graphics.** Headers and wings available in UV printed graphics or frosted plex. Kits come with two lights and ship in durable storage cases. Options include LCD monitor mounts, tables, counters, literature pockets and larger freight cases. Customized units also available.



LN-K-3P-22



LN-K-3P-25

10'

20'

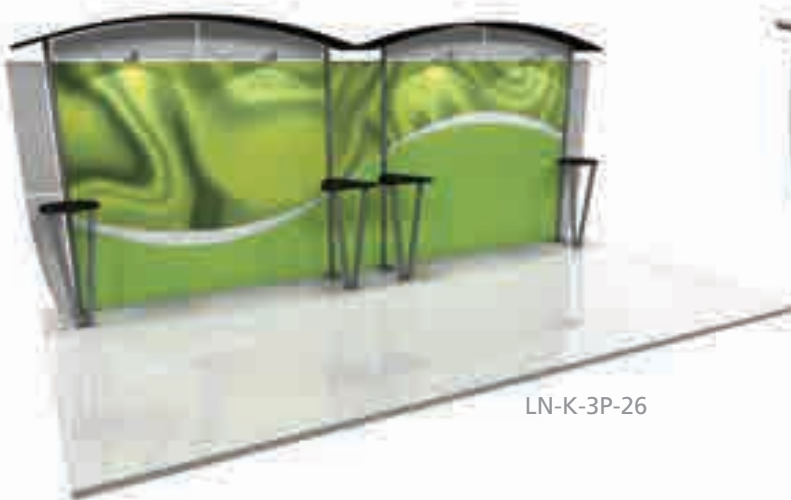

LN-K-3P-26

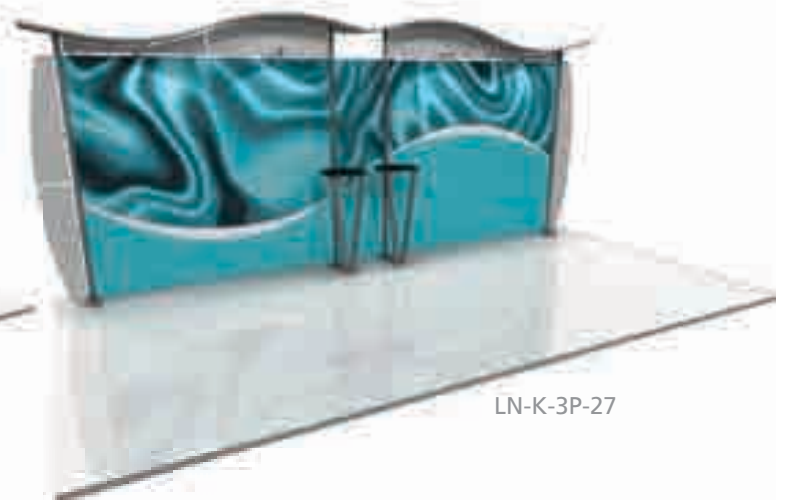

LN-K-3P-27

LINEAR BOLD

Linear Bold Kits command attention with a heavy-duty aluminum structure and functional, yet stylish features. These hybrid modular displays feature center panel, side and accent headers, tables and lights and ship in durable storage cases. Options include LCD monitor mounts, tables, counters, literature pockets and larger freight cases. Customized units also available.



Linear counter tops are available in your choice of four thermoform finishes

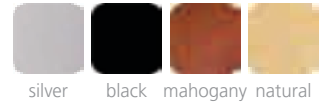

LN-K-31



LN-K-37

10'

20'

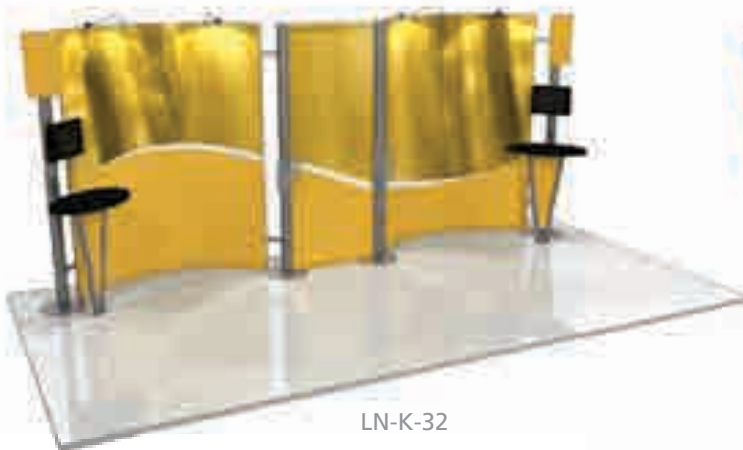

LN-K-32



LN-K-38

LINEAR ACCESSORIES



Literature Pocket LN112



Monitor Bracket 1 LN-LCD1-B
13" - 27" LCD
max weight = 50 lbs



Monitor Bracket 2 LN-LCD2-B
26" - 42" LCD
max weight = 80 lbs

Linear counter bases are available in your choice of four laminate options



LINEAR BOLD COUNTERS



dove gray black designer white fusion maple

Dress up your space with sophisticated and functional counters. Counter tops are available in four thermoform finishes – silver, black, mahogany and natural. Printed graphic panels are available in four laminate colors – dove gray, designer white, black, and fusion maple. Custom counter top colors and graphic colors are available.



LN-CU-01



LN-CU-02



LN-CU-03



LN-CU-05



LN-CU-06



LN-CU-07



LN-CU-08

LINEAR KIOSKS



Linear Kiosks provide unique design elements for a custom look. Aluminum construction coupled with rigid graphic infill panels make these kiosks durable and long lasting.

each Linear kiosk comes with an OCH2 case



LINEAR KIOSKS



LINEAR KIOSK 01
LN-K-01

- 54.4" w x 99" h x 23.25" d
- monitor mount
- fabric canopy
- approximate weight: 125 lbs



LINEAR KIOSK 02
LN-K-02

- 47.25" w x 96.85" h x 23.25" d
- monitor mount
- fabric canopy
- approximate weight: 130 lbs



LINEAR KIOSK 03
LN-K-03

- 47.33" w x 96.85" h x 23.25" d
- fabric canopy
- approximate weight: 115 lbs



LINEAR KIOSK 04
LN-K-04

- 63" w x 96.85" h x 30" d
- 50 watt spotlight
- approximate weight: 90 lbs

Linear kiosk counter tops are available in your choice of four thermoform finishes

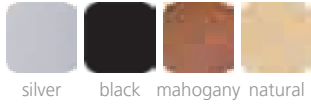

silver black mahogany natural



LINEAR KIOSKS

Linear Monitor Kiosks add function and flare to any space. Extrusion-based construction coupled with your choice of rigid graphic infill panels or frosted plex panels make these kiosks sturdy and versatile.



LINEAR KIOSK 05
LN-K-05

- 25.38" w x 72.25" h x 18.5" d
- monitor mount
- approximate weight: 30 lbs



LINEAR KIOSK 06
LN-K-06

- 25.38" w x 72.25" h x 18.5" d
- monitor mount
- approximate weight: 27 lbs



LINEAR KIOSK 07
LN-K-07

- 24" w x 86" h x 21" d
- monitor mount
- approximate weight: 49 lbs



LINEAR KIOSK 08
LN-K-08

- 23.5" w x 86" h x 17.75" d
- monitor mount
- approximate weight: 46 lbs

LINEAR COUNTER

LN-TBL-SA-RCT

- coordinates with the Linear hybrid modular display line
- 3 graphic panels available to display your custom graphics
- quick & easy to assemble, tool included
- fits in an OCH shipping and transport case
- aluminum design is sturdy and stable



HOPUP COUNTER

HOP-CT-S

- collapsible display counter
- very portable & lightweight
- includes black internal shelf
- hinged top available in all four laminate finishes



counter tops are available in your choice of finishes

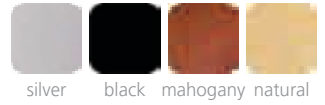

CAMPAIGN

CP-B2

- quick assembly
- strong & easy to clean plastic parts



V-CLASS COUNTER

- your choice of four standard patterns, custom graphic option also available
- contoured design creates a refined, substantial look
- quick & simple assembly
- wire management option available
- comes with an OCH shipping & transport case



repositionable shelves adjust to your storage needs

sides are available in your choice of printed patterns

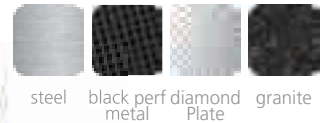

counter stretch skirts are available in the following colors



amethyst ruby sapphire emerald silver jet



SYMPHONY COUNTER

Symphony counters unique, sleek design lends an attractive element to your tradeshow or P.O.P. display. These counters are quick to set-up, with easy assembly. The modern colors draw attention to your booth and are a perfect complement to any display.



Oval
SYM-OV



Quad
SYM-QD



Rectangle
SYM-RCT



Bullet
SYM-BLLT



Oval Grand
SYM-OV-GRND



Quad Grand
SYM-QD-GRND



Oval Double Grand
SYM-OV-DBL-GRND



3 Quad Kit
SYM-QD-3



Corner Kit
SYM-CRNR

BREEZE

90 DAY

BREZ-1-S: 8.375" w x 13" h
BREZ-2-S: 11" w x 17" h

- retractable tabletop stand
- ideal for custom calendars & other promotional banners



VORT-X MINI

90 DAY

red: VTX-MC
blue: VTX-MC-BL

- quick & simple to assemble
- ideal for retail/P.O.P. use
- sold in packs of 2
- visual area = 12" w x 16.5" h



TABLE ACE

90 DAY

TB-ACE-1: 6" w x 12" h
TB-ACE-2: 6" w x 24" h
TB-ACE-3: 12" w x 24" h

- mini tabletop banner stands
- sold in packs of 3
- black only



L-MINI
LMINI

ONE YEAR

- standard height = 26.875" h
- tabletop tension banner stand
- adhesive rail
- anodized silver finish



NEW

APEX

ONE YEAR

APEX

- double-sided plastic a-frame
- can be printed directly on the plastic for a smooth look
- for indoor or outdoor use



SYNERGY

ONE YEAR

SYN-2-1

- double-sided aluminum a-frame
- snap edges for quick graphic changes
- silver anodized finish



OASIS

ONE YEAR

OASIS

- highly portable
- three arm collapsible bag dispenser
- shiny silver finish



STEP STOOL

ONE YEAR

STEP STOOL

- sturdy EZ FOLDZ step stool
- 300 lb capacity
- folds flat for storage & transport
- red only



WEDGE

FIVE YEAR

WED-B

- combine multiple units for longer and taller displays
- graphic size is variable
- black only
- graphics not included



TOWER

ONE YEAR

- quick to set up
- 24" and 33" widths available
- tower height = 72"
- lightbox conversion option
- available in black or silver
- large graphic display area



NEW

POSTER SNAPPER

FIVE YEAR

- snap edges for quick graphic changes
- S-hook or nylon line mount options
- comes in 4 standard lengths
- custom lengths available



NEW

TRAPPA POSTER FRAME

- black or silver anodized finish w/ precision mitered corners
- spring loaded aluminum extrusions mounted to a high-impact polystyrene backer
- available in a wide range of standard sizes & includes a clear anti-glare lens



FIVE YEAR





ZEDUP 1

black: ZD-1-B
silver: ZD-1-S

- 6 pocket rack
- can be stored or shipped loaded with literature



hard case upgrade:
black: ZD-1-HC-B
silver: ZD-1-HC-S



ZEDUP LITE

silver: ZD-LITE

- 6 pocket rack
- collapsible
- lightweight version of the ZedUp
- constructed from aluminum & plastic for reduced weight



INNOVATE

black: INN-B
silver: INN-S

- modular design
- 10 pockets
- packs in 3 separate parts for reduced shipping size



TITAN

black: TITN-B

- modular design
- heavy duty
- 8 pocket
- packs in 3 separate parts for reduced shipping size



ILLUSION

black: IL-1-B
silver: IL-1-S

- fast-folding cantilever rack
- 4 front facing pockets



VICTORY

black: VIC-B
silver: VIC-S

- slim, modular, snap-together design



10 UP

black: 10UP-B

- strong & stable
- 10 pockets
- packs flat

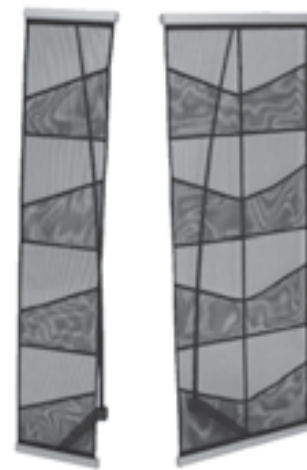

LR 1 & LR 2

4 pocket: LR-1
8 pocket: LR-2

- modular, roll-up mesh design
- holds standard 8.5" w x 11" h literature
- 4 or 8 pocket model
- black with chrome accent



All literature racks come with a five year warranty, a carry bag, and are an eco-friendly choice.

OCA2

OCA2

- attaches to the OCFM or OCHM
- ideal for lights and accessories
- secure straps help to assure case will remain closed during transport
- interior size: 32.75"l x 13.5"w x 4.25"h
- exterior size: 34"l x 15"w x 7"h
- weight when empty: 8 lbs



OCB

OCB

- this expandable shipping case fits up to three swivel-foot stands with bags or one premium stand with bag*
- interior size min/max: min - 28.375"l x 12"w x 3.375"h / max - 44.25"l x 12"w x 3.375"h
- exterior size min/max: min - 31"l x 17"w x 7"h / max - 47"l x 17"w x 7"h
- weight when empty: 9 lbs
- *case does not fit Orchid, Dash, Uno, Spring 5, Contender 48 or banners over 39.37" wide



OCP

OCP

- light storage in the lid
- secure reinforced straps help to assure case will remain closed during transport
- interior size: 35"l x 21.5"w x 12.25"h
- exterior size: 40"l x 27"w x 18"h
- weight when empty: 21 lbs



OCP2

OCP2

- premium latches for maximum strength
- hinged lid with internal light storage
- robust, roto-molded plastic
- interior size: 22.5"w x 35"h x 13.13"d
- exterior size: 25.88"w x 40.5"h x 18"d
- approximate weight when empty: 100 lbs



OCP ELITE

OCP-ELITE

- lid can be used as a step stool while assembling displays
- access door provides storage when unit is used as a counter
- interior size: 35"l x 21"w x 14.25"h
- exterior size: 39"l x 27"w x 18"h
- weight when empty: 31 lbs



OC-HOP

OC-HOP

- ideal for Hopup backwall displays (fits up to 3x3 hopup)
- built-in handle and wheels for easy transport
- interior size: 34"l x 14"w x 14"h
- exterior size: 36"l x 18"w x 18"h
- weight when empty: 17 lbs



OCH

OCH

- blow molded case for exhibits, graphics & accessories
- secure reinforced straps help to assure case will remain closed during transport
- strong yet lightweight
- interior size: 47.25"l x 23.75"w x 8"h
- exterior size: 50"l x 29"w x 12"h
- weight when empty: 22 lbs



OCH2

OCH2

- heavy-duty shipping and storage case
- ideal for Linear hybrid displays
- secure reinforced straps help to assure case will remain closed during transport
- interior size: 48.25"l x 24"w x 14"h
- exterior size: 52"l x 30"w x 15"h
- weight when empty: 30 lbs



OCHM

OCHM

- interlocking surface to enable two cases to be transported together
- maximum case depth = 8" allowing up to 8 flat panels per case
- interior size: 36.5"l x 23.75"w x 9"h
- exterior size: 38"l x 28"w x 13"h
- weight when empty: 20 lbs



OCS AND OCL

small: OCS
large: OCL

- secure reinforced straps help to assure case will remain closed during transport

OCL

- interior size: 13.5"l x 13.5"w x 50"h
- exterior size: 19"l x 19"w x 56"h
- weight when empty: 20 lbs

OCS

- interior size: 13.5"l x 13.5"w x 39.5"h
- exterior size: 19"l x 19"w x 45"h
- weight when empty: 18 lbs



OCFM

OCFM

- interlocking surface to enable two cases to be transported together
- maximum case depth= 8" allowing up to 8 flat panels per case
- interior size: 27.25"l x 35.75"w x 9.5"h
- exterior size: 49"l x 39"w x 15"h
- weight when empty: 35 lbs

OCF

OCF

- offers the same features and benefits of the OCT in a rectangular shape
- interior size: 47.25"l x 35.75"w x 18"h
- exterior size: 51"l x 38"w x 24"h
- weight when empty: 55 lbs

OCF2

OCF2

- molded stackable shipping crate 18" deep
- heavy-duty roller bearing recessed in bridge of case
- holds 18 layers of flat panels in horizontal direction
- interior size: 47.25"l x 47.25"w x 18"h
- exterior size: 51"l x 51"w x 24"h
- weight when empty: 70 lbs



OCM

OCM

- black LLDPE Polyethelene case designed for LCD monitors
- built in dry erase board to label contents and location
- fits 37" - 47" screens
- includes 3" casters with rubber wheels
- must be shipped freight
- interior size: 45.5"l x 5"w x 30"h
- exterior size: 54"l x 16"w x 35"h
- weight when empty: 55 lbs



OCT

OCT

- designed to handle national & international exhibit freight shipments
- offers maximum protection for your exhibit materials
- interior size: 47.5"w x 34.5"h x 44.25"d
- exterior size: 50"l x 47"w x 43"h
- weight when empty: 138 lbs



All cases come with a one year warranty, are an economic & eco-friendly choice, & made in the USA.



LUMINA 1

black: LUM-1-B
chrome: LUM-1-C

- low voltage 50 watt spotlight & universal fittings kit
- "goose neck" arm
- mounts horizontally
- LED option available



LUMINA 2

LUM-2-1

- low voltage 50 watt slender spotlight
- mounts to a vertical pole
- brushed stainless steel finish
- LED option available

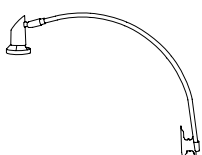

LUMINA 3

LUM-3

- low voltage 50 watt spotlight, chrome with a black head & universal fittings kit
- telescopic arm
- extends from 7"-22" long
- LED option available

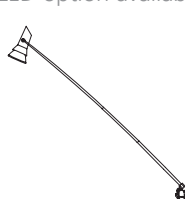

LUMINA 5

LUM-5

- low voltage 50 watt spotlight & universal fittings kit
- deluxe chrome head
- telescopic arm
- extends from 7"-22" long
- LED option available



LUMINA 6

LUM-6

- low voltage, 50 watt spotlight & universal fittings kit
- stylish curved twin arms
- silk black only
- LED option available

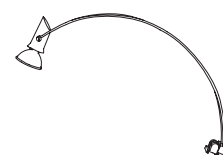

LUMINA 7

LUM-7

- incandescent 110 volt fixture
- dovetail mount
- 45 watt incandescent bulb included
- silk black only

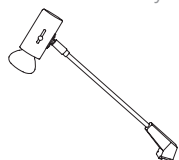

LUMINA 8

black: LUM-8-B
silver: LUM-8-C

- 12 volt spotlight with straight arm & adjustable head
- includes 110 volt UL approved transformer, 50 watt bulb & universal fittings kit
- 17" (431.8 mm) long from end to end
- LED option available

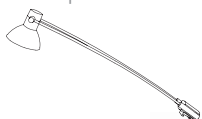

LUMINA 200

LUM-200-ORL

- 110 volt ETL approved wall washer floodlight with a straight arm & adjustable head
- light includes 120 watt halogen bulb
- 19.5" (495.3 mm) long from end to end
- silk black finish

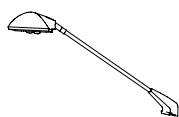

LUMINA 200 LED

LUM-LED-ORL-B

- LED version of the Lumina 200 floodlight
- 1400 Ma, 12 VDC
- LED rated for 20,000 continuous hours

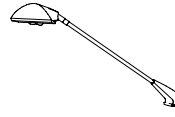

SPT CASE

SPT-CASE

- EVA semi-rigid lighting case
- foam-lined padded compartments
- holds two Lumina lights & power supply



FLD CASE

FLD-CASE

- EVA semi-rigid lighting case
- foam-lined padded compartments
- stores & transports two lights
- designed for use with Lumina models 1-5



UNIVERSAL LIGHT CLAMP KIT

UNI-LT-CLP

- comes standard with the Lumina 1, 3, 4, 5, 6, 8 and allows our lights to fit a majority of banners, truss & panel kits



LUMINA SPARE BULB KIT

LUM-BULB

- (2) 50 watt low voltage spare bulbs in a padded, protective EVA formed case



LED BULB OPTION

LUM-LV-LED-BLB16

- a green solution for Lumina 1, 2, 3, 4, 5, 6, 8
- 50 watt LED bulb



wayfinding signage solutions available at:

www.SIGNMAKERS-HANDBOOK.com

featuring a wide range of configurations for a consistent look throughout your building

INFO CENTERS
TRIANGULAR SIGNS
DESK FRAMES
SUSPENDED SIGNS

FREE STANDING PYLONS
WALL-FRAMES
PROJECTING SIGNS
DIRECTORIES



user-friendly, versatile, affordable solutions | front-loading design for easy graphic change

CONTACT US FOR OPTIONS, SPECS & DIMENSIONS



BROUGHT TO YOU BY:

www.exhibitors-handbook.com

**America's
Favorite
Tradeshow
Supplier**